

Engineering Specification

W-300-H-X-*D-PP (Non-reversing)

W-300-HAC-X-*D-PP (Reversing)

Commercial Water to Water Heat Pump / Chiller

Dual Refrigeration Circuit, R454b, 60 Hz

Heating/Cooling or Ice Making/Arena Application

Nominal Size 23 Ton

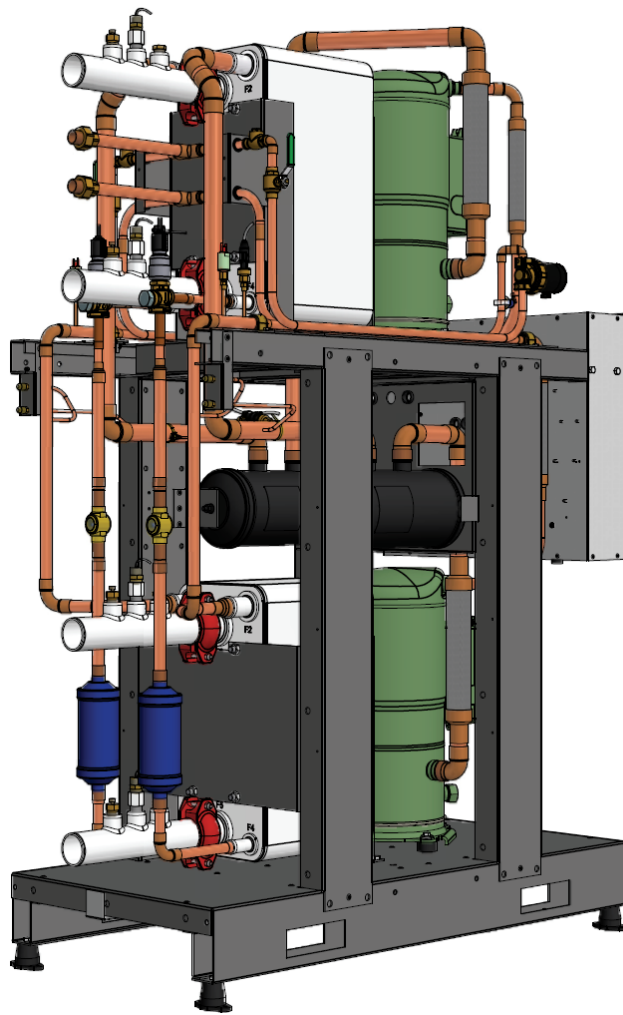

C US

Maritime Geothermal Ltd.
P.O. Box 2555, 170 Plantation Road
Petitcodiac, NB E4Z 6H4
(506) 756-8135

info@nordicghp.com
www.nordicghp.com
002765SPC-01

Model Nomenclature

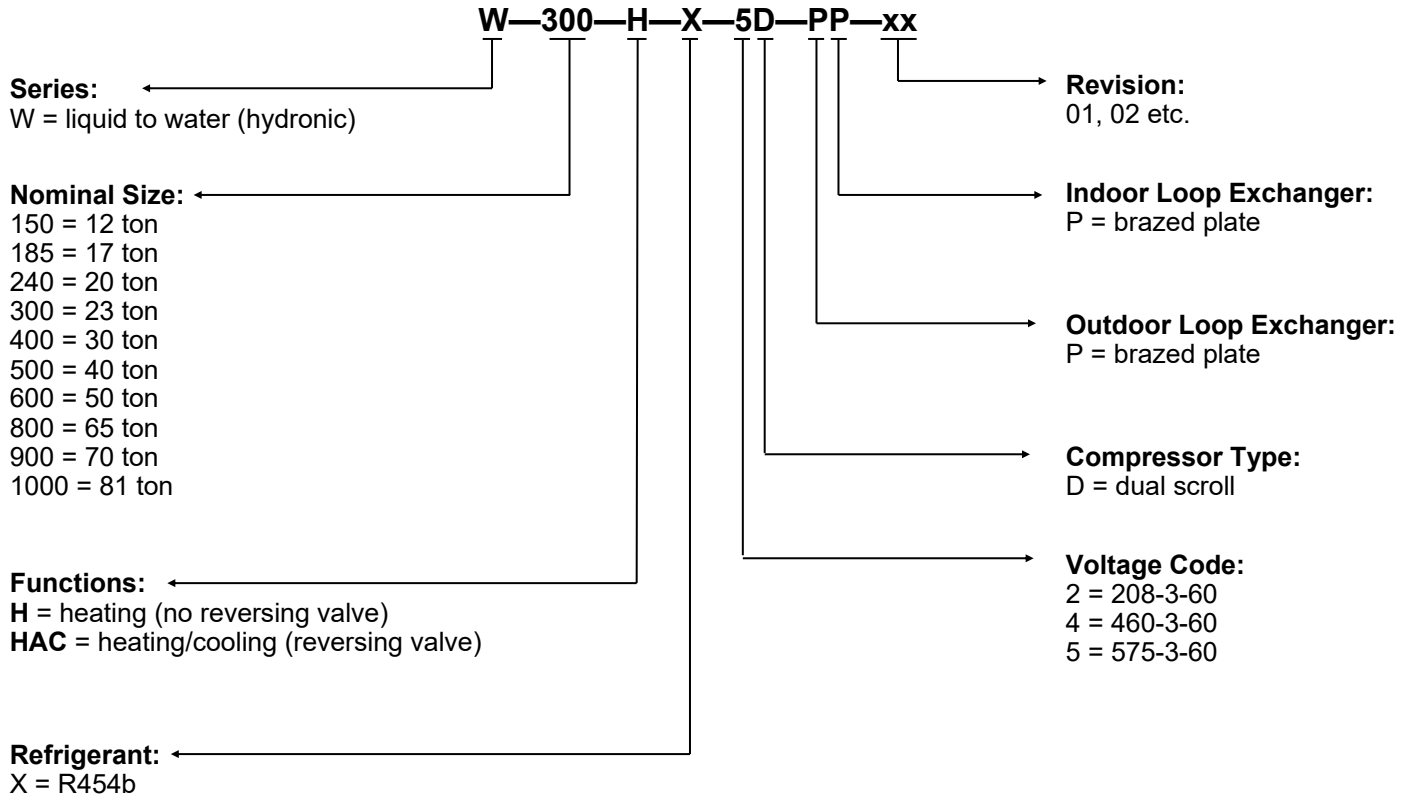

APPLICATION TABLE										
MODEL SIZE	FUNCTION	REFRIGERANT	VOLTAGE	COMPRESSOR	OUTDOOR COIL	INDOOR COIL	REVISIONS			
W-300	H HAC	X	2 4 5	D	P	P	01			

This document applies only to the models and revisions listed in this table.

Maritime Geothermal Ltd. has a continuous improvement policy and reserves the right to modify specification data at any time without prior notice .

Design Features

- R454b refrigerant (GWP=466) is climate change-friendly. Note that R454b has an **A2L** classification.
- Suitable for space heating/cooling, heat recovery, or ice making/arena applications
- TUV listed for electrical certification
- 11 gauge heavy duty standalone frame with slots for 4-side fork lift access
- Rubber mounting feet (optional spring foot kit, below)
- Insulated heat exchangers and piping
- Dual refrigeration circuits: each circuit operates independently
- Bitzer Orbit scroll compressors with crankcase heaters
- Suction and discharge vibration absorbers (each circuit)
- Suction line accumulator (each circuit)
- Liquid line solid core filter-dryer (each circuit)
- Liquid line sight glass (each circuit)
- Electronic Expansion Valves (EEVs) (each circuit)
- 4-way reversing valve on reversing **-HAC** units (each circuit)
- Refrigeration service ports for each refrigeration circuit (1/4" Schrader)
- 316 stainless steel brazed plate heat exchangers
- 316 stainless piping with 2" Victaulic connections for the outdoor and indoor loops
- 3-phase protection
- High and low pressure sensors (each circuit)
- Suction line temperature sensor (each circuit)
- Manual reset high pressure control (each circuit)
- Flow switch for outdoor loop, and also for indoor loop on reversing **-HAC** units
- Temperature sensor and P/T port on all four water lines (Outdoor In, Outdoor Out, Indoor In and Indoor Out)
- Advanced control board with BACNet interface for remote operation and data access including all sensor data and alarm conditions, PWM outputs (or 0-10VDC), configurable analog inputs (0-10VDC or 4-20mA) with on board 5VDC, 12VDC and 24VDC power supplies.
- USB port for complete data access using laptop computer and provided software; including real-time charting, data logging, and diagnostic functionality with manual override operation
- 2 x 16 LCD display for control and data access
- Random start on power up (0-2 minutes)
- Dry contacts for external pump control (24VAC 5A MAX)
- 16ga satin galvanized acoustically insulated (1" thick) enclosure with powder coat finish and six removable panels, offering complete 360 degree access for servicing

Available Accessories

- Spring foot kit, for use where floors have deflection (e.g. mezzanines)
- Tank temperature sensor(s) for standalone configuration
- Factory headers for multiple units

Design Features

Dual refrigeration circuit design allows independent operation of each compressor using its own refrigeration circuit.

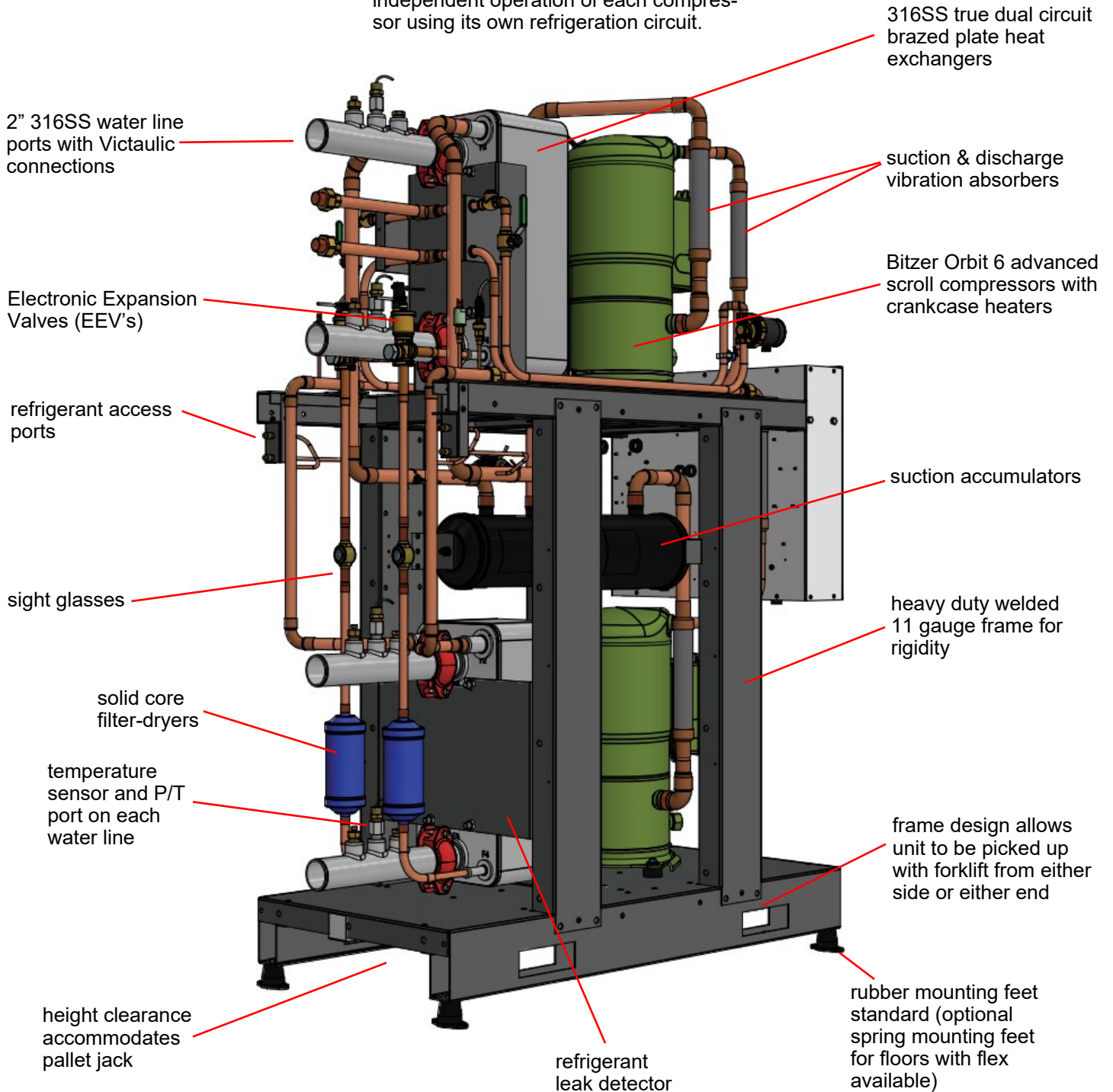

Suitable for open or closed loop applications.

Design Features

ENCLOSURE

heavy duty enclosure
constructed of 16ga satin
galvanized steel, with powder
coat finish

completely insulated
with 1" acoustic
insulation

seven removeable
access panels;
side panels can be
removed from end
when multiple units
are installed side
by side (no side
access required)

2" Victaulic
connections
for loops

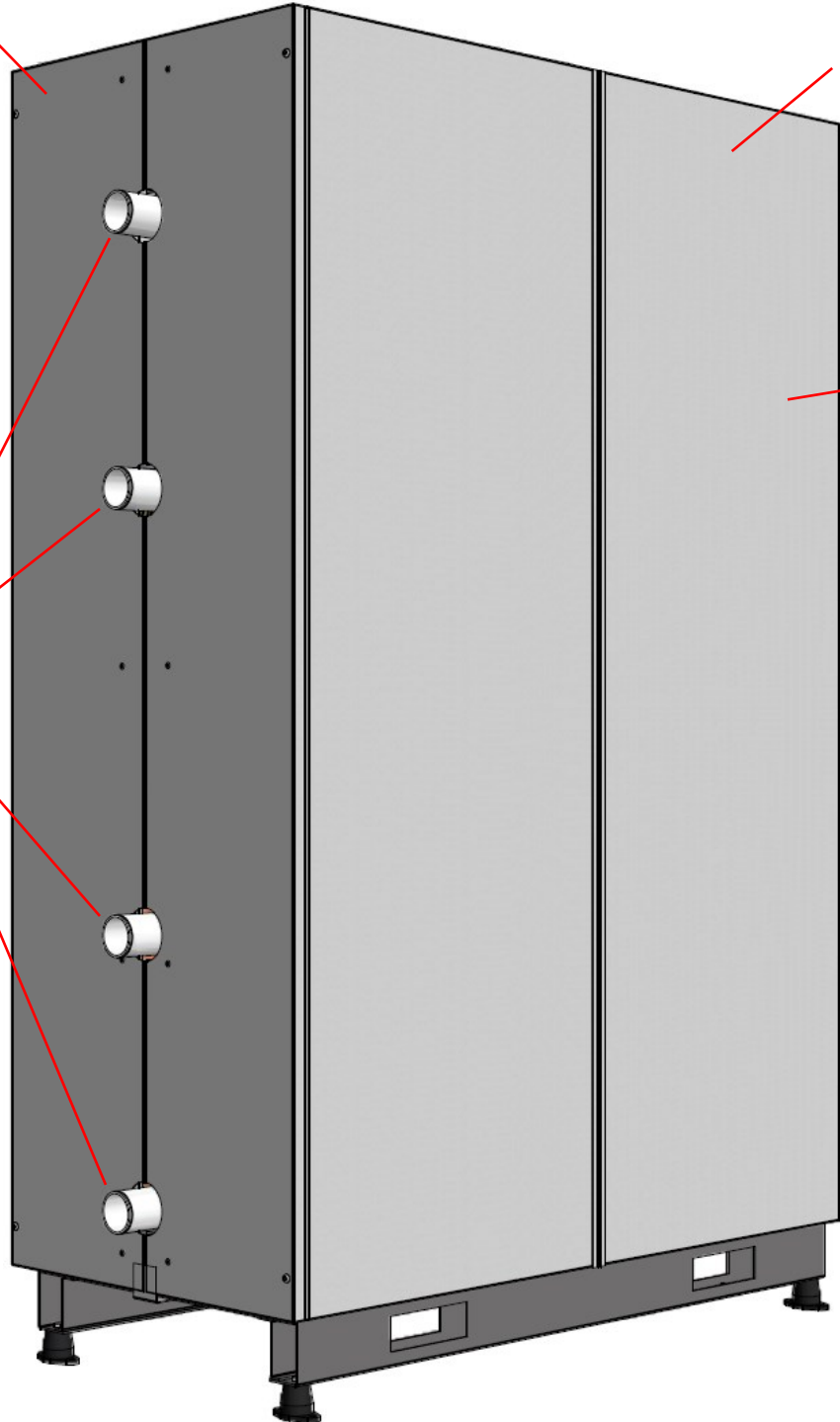

Dimensions

WITHOUT ENCLOSURE

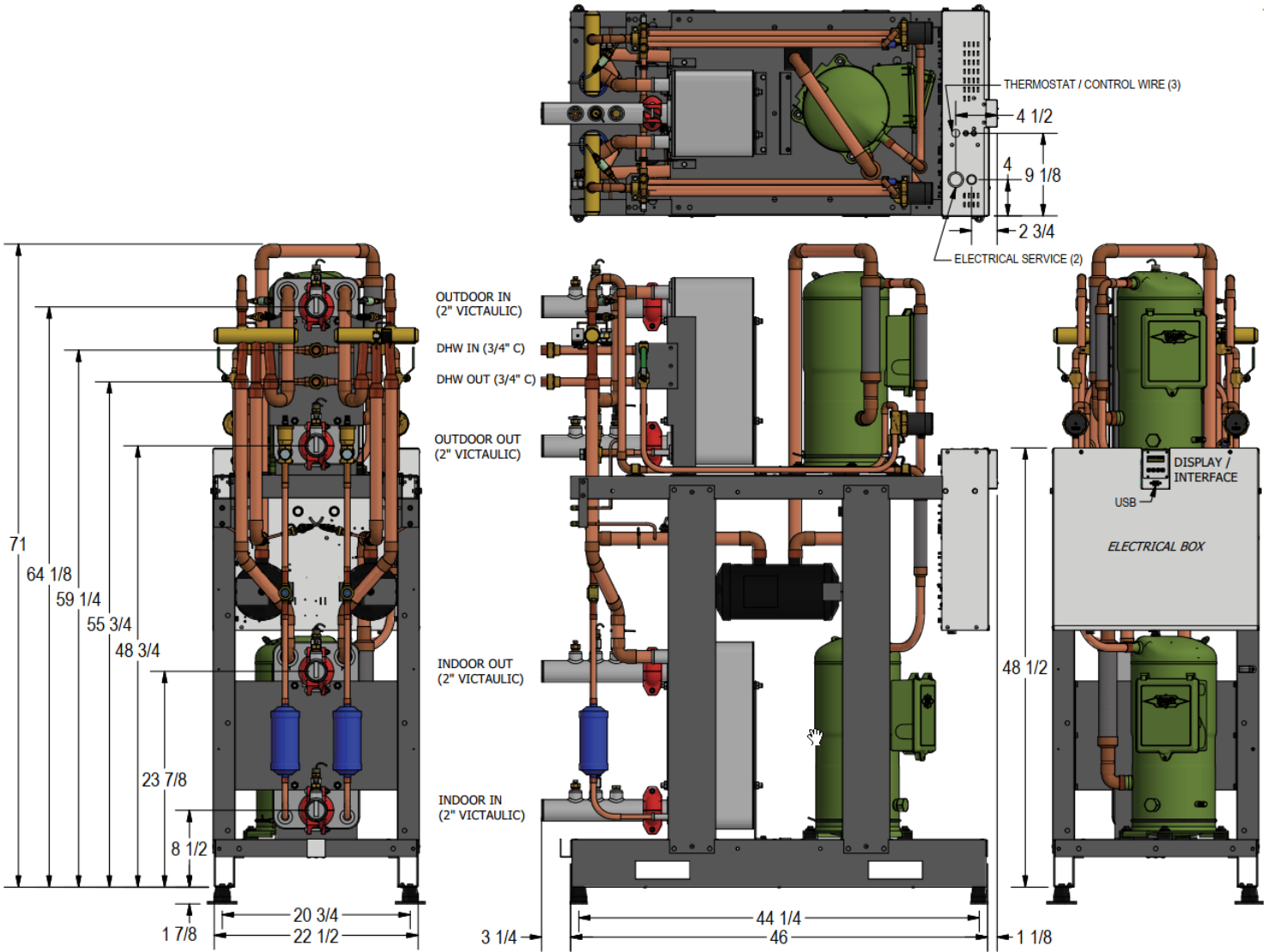

All dimensions in inches.

Dimensions

WITH ENCLOSURE

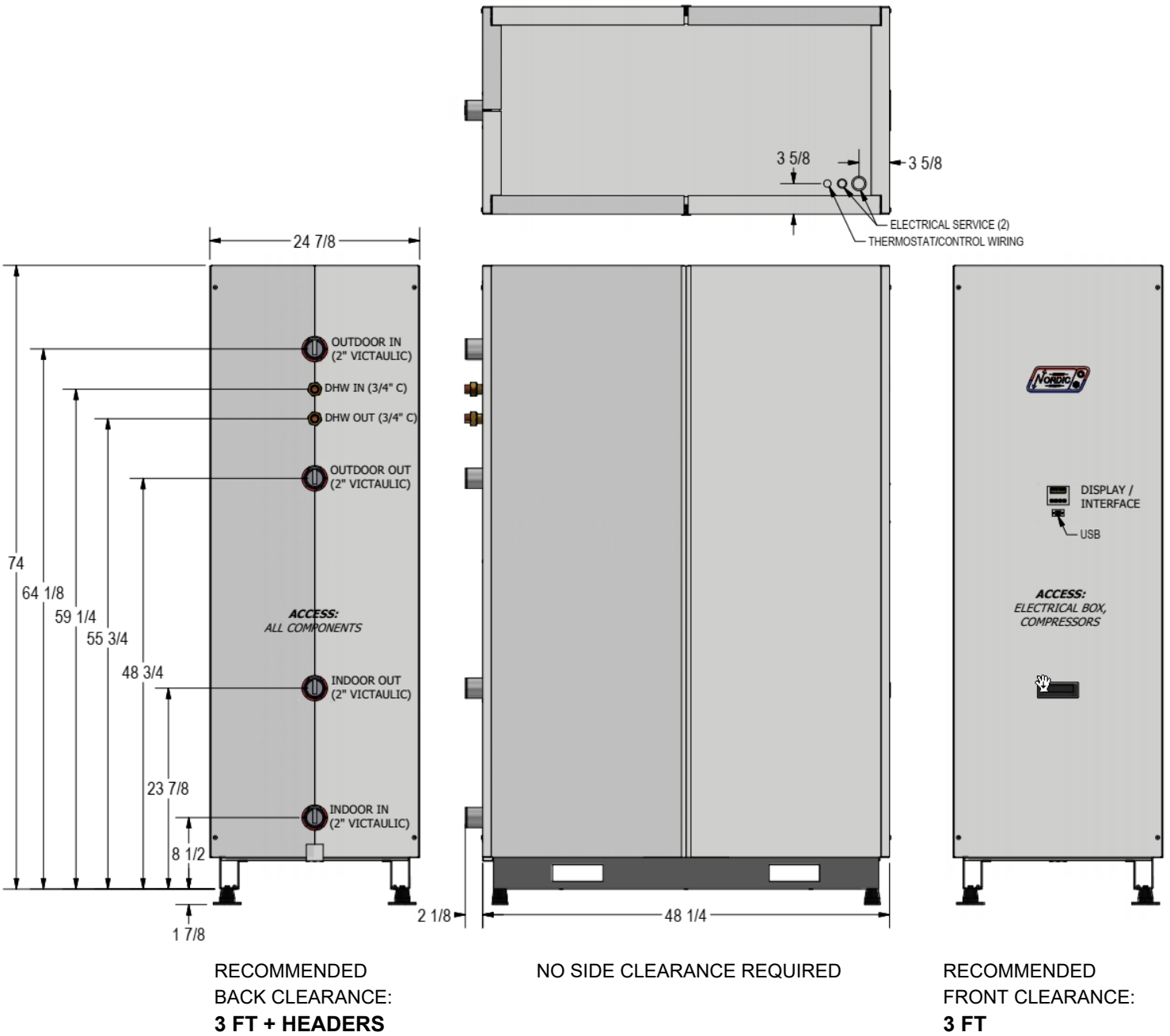

All dimensions in inches.

Specifications

Electrical Specifications (R454b)									
Nomenclature Identifier	Power Supply			Compressors (each)		FLA	MCA	Maximum Fuse/Breaker *	Minimum Wire Size*
	V-ø-Hz	MIN	MAX	RLA	LRA	Amps	Amps	Amps	ga
2	208-3-60	187	229	44.2	252	89.3	100.4	125	#2-3
4	460-3-60	414	506	22.6	137	45.7	51.4	60	#6-3
5	575-3-60	518	632	19.2	103	38.9	43.7	60	#6-3

* Wire and breaker sizes should be verified by a qualified professional to verify conformance to local codes.

Refrigerant Charge (Per Circuit)				
MODEL	TYPE	lb	kg	Oil Type
W-300	R454b	11	5.0	PVE-BVC32

- Oil capacity is marked on the compressor label.
 - Refrigerant charge is subject to revision; actual charge is indicated on the unit nameplate.

Shipping Information				
MODEL	WEIGHT lb. (kg)	DIMENSIONS in (cm)		
		L	W	H
W-300	1386 (630)	78 (198)	32 (81)	82 (208)

Standard Capacity Ratings - Ground Loop Heating* 60Hz						
EWT 104°F (40°C)			ELT 32°F (0°C)			
Model	Liquid Flow (Outdoor & Indoor)		Input Energy	Capacity		COP _H
	gpm	L/s	Watts	Btu/hr	kW	W/W
W-300	72	4.5	18,194	218,100	64	3.51

* 35% Propylene Glycol by Volume Outdoor (Ground) Loop Fluid

Standard Capacity Ratings - Ground Water Heating 60Hz						
EWT 104°F (40°C)			ELT 50°F (10°C)			
Model	Liquid Flow (Outdoor & Indoor)		Input Energy	Capacity		COP _H
	gpm	L/s	Watts	Btu/hr	kW	W/W
W-300	72	4.5	19,340	312,800	92	4.74

Standard Capacity Ratings - Ground Loop Cooling* 60Hz							
EWT 53.6°F (12°C)				ELT 77°F (25°C)			
Model	Liquid Flow (Outdoor & Indoor)		Input Energy	Evap. Capacity		COP _c	EER
	gpm	L/s	Watts	Btu/hr	kW	W/W	Btu/hr/W
W-300	72	4.5	16,180	262,100	77	4.75	16.2

* 35% Propylene Glycol by Volume Outdoor (Ground) Loop Fluid

Standard Capacity Ratings - Ground Water Cooling 60Hz							
EWT 53.6°F (12°C)				ELT 59°F (15°C)			
Model	Liquid Flow (Outdoor & Indoor)		Input Energy	Evap. Capacity		COP _c	EER
	gpm	L/s	Watts	Btu/hr	kW	W/W	Btu/hr/W
W-300	72	4.5	12,918	282,900	83	6.42	21.9

Specifications

Flow Rates & Volumes									
MODEL	Nominal Size (60Hz) tons	Recommended Liquid Flow (Outdoor & Indoor Loops)				Heat Pump's Indoor Loop Holdup Volume		Heat Pump's Outdoor Loop Holdup Volume	
		100% CAPACITY (2 COMPRESSORS)		50% CAPACITY (1 COMPRESSOR)		US gal	L	US gal	L
		gpm(US)	L/s	gpm(US)	L/s				
W-300	23	72	4.5	36	2.3	3.54	13.4	3.54	13.4

Loop Pressure Drop Data			INDOOR (water 130°F)		INDOOR (water 104°F)		OUTDOOR (water 50°F)		OUTDOOR (15% methanol 32°F)		OUTDOOR (35% prop.glycol 32°F)		
MODEL	gpm	L/s	psi	kPa	psi	kPa	psi	kPa	psi	kPa	psi	kPa	
	W-300	36	2.3	0.7	4.8	0.7	4.8	0.8	5.5	0.9	6.2		
40		2.5	0.9	6.2	0.9	6.2	1.0	6.9	1.1	7.6	2.1	15	
48		3.0	1.2	8.3	1.2	8.3	1.3	9.0	1.4	9.7	2.5	17	
60		3.8	1.7	12	12	1.8	12	1.9	13	2.1	15	3.1	21
72		4.5	2.5	17	17	2.6	18	2.7	19	2.9	20	3.7	26
90		5.7	3.9	27	27	4.0	28	4.1	28	4.4	30	4.8	33

W-SERIES Operating Temperature Limits					
Loop	Mode	Parameter	(°F)	(°C)	Note
Indoor Loop	HEATING (indoor is hot loop)	Minimum ELT/EWT	50	10	0-10VDC modulating water valve required on indoor loop at temperatures < 80°F (27°C), or manual flow reduction at startup
		Maximum LLT/LWT	130	54	
	ICE production	Maximum LLT/LWT	110	43	Maximum hot loop temperature during ICE production (specify ICE duty at order).
	COOLING (reversing HAC units only, indoor is cold loop)	Minimum LWT	40	4	Indoor loop with water only (no antifreeze).
		Minimum LLT	-->	-->	Indoor loop with antifreeze: depends on antifreeze type & %
		Maximum ELT	80	27	0-10VDC modulating water valve required on indoor loop above this temperature, or manual flow reduction at startup
Outdoor Loop	HEATING (outdoor is cold loop)	Minimum LWT	37	3	For water loops without antifreeze, e.g. open loop systems
		Minimum LLT	-->	-->	Ground loop system: depends on antifreeze type and % settings.
		Maximum ELT/EWT	80	27	0-10VDC modulating water valve required on outdoor loop above this temperature to limit suction pressure
	ICE production	Minimum LLT	0	-17	Minimum cold loop temperature during ice production (specify ICE duty at order).
	COOLING (reversing HAC units only, outdoor is hot loop)	Minimum ELT/EWT	50	10	0-10VDC modulating water valve required on outdoor loop at temperatures < 80°F (27°C) to keep head pressure up
		Maximum LLT/LWT	130	54	

ELT: Entering Liquid Temperature (implies antifreeze present)
 LLT: Leaving Liquid Temperature (implies antifreeze present)
 EWT: Entering Water Temperature
 LWT: Leaving Water Temperature

Values in these tables are for rated liquid and water flows.

Performance Tables - W-Series (US UNITS)

W-300-H-X*-D-PP** R454b, 60 Hz, 2 x GSD60137VL (460-3-60)

*Compressor current is for 460-3-60.
Multiply by 2.2 for 208-3-60, by 0.8 for 575-3-60.

LOW TEMPERATURE	EVAPORATOR LOOP (50% Propylene Glycol)							ELECTRICAL		CONDENSER LOOP (Water)						
	ELT (°F)	Evap. Temp.	Flow (gpm)	LLT (°F)	Delta T (°F)	Ice Cooling (Btu/hr)	EER	Compressor Current (A)*	Input Power (W)	EWT (°F)	Cond. Temp.	Flow (gpm)	LWT (°F)	Delta T (°F)	Heating (Btu/hr)	COP _H
LOW TEMPERATURE	5	-3	72	2	-2.7	84,200	6.6	19.8	14,288	85	95	72	89	3.6	128,800	2.64
	10	2	72	7	-3.1	96,000	7.2	20.4	14,609		95	72	89	3.9	142,200	2.85
	15	6	72	12	-3.5	108,900	7.9	21.0	14,905		95	72	89	4.3	156,600	3.08
	20	10	72	16	-3.9	122,700	8.7	21.6	15,181		96	72	90	4.8	171,900	3.32
	25	15	72	21	-4.4	137,800	9.5	22.2	15,434		96	72	90	5.2	188,400	3.58
	30	19	72	25	-4.9	154,000	10.3	22.7	15,700		97	72	91	5.7	206,000	3.85
	35	24	72	30	-5.5	171,500	11.1	23.3	15,974		97	72	91	6.3	225,000	4.13
	40	28	72	34	-6.0	190,200	12.0	23.9	16,269		97	72	92	6.8	245,300	4.42

HEATING	EVAPORATOR LOOP (35% Propylene Glycol)						ELECTRICAL		CONDENSER LOOP (Water)						
	ELT (°F)	Evap. Temp.	Flow (gpm)	LLT (°F)	Delta T (°F)	Heat Abs. (Btu/hr)	Compressor Current (A)*	Input Power (W)	EWT (°F)	Cond. Temp.	Flow (gpm)	LWT (°F)	Delta T (°F)	Heating (Btu/hr)	COP _H
HEATING	25	15	72	21	-3.9	129,400	25.0	17,813	104	115	72	109	5.3	188,800	3.11
	30	19	72	26	-4.5	149,000	25.3	18,089		115	72	110	5.8	209,400	3.39
	35	24	72	30	-5.1	170,600	25.7	18,353		116	72	111	6.5	231,900	3.70
	40	29	72	34	-5.8	193,800	26.1	18,652		116	72	111	7.1	256,100	4.02
	45	34	72	38	-6.6	219,900	26.5	18,964		117	72	112	7.9	283,300	4.38
	50	38	72	43	-7.4	248,100	27.0	19,340		117	72	113	8.7	312,800	4.74
	55	43	72	47	-8.3	278,300	27.6	19,767		118	72	114	9.6	344,500	5.11
	60	48	72	51	-9.3	312,200	28.2	20,249		118	72	115	10.6	380,000	5.50
	65	53	72	55	-10.4	348,500	28.9	20,836		119	72	116	11.7	418,300	5.88
	70	58	72	59	-11.5	388,300	29.8	21,499		120	72	117	12.9	460,400	6.28
	25	15	72	22	-3.5	117,500	27.0	19,517	115	124	72	120	5.1	182,700	2.74
	30	20	72	26	-4.1	136,800	27.4	19,782	114	124	72		5.7	203,000	3.01
	35	24	72	30	-4.7	158,200	27.8	20,053	114	124	72		6.3	225,300	3.29
	40	29	72	35	-5.4	181,600	28.2	20,366	113	125	72		7.0	249,800	3.59
	45	34	72	39	-6.2	207,500	28.6	20,687	112	125	72		7.8	276,800	3.92
	50	39	72	43	-7.0	236,100	29.1	21,055	111	125	72		8.6	306,600	4.27
	55	44	72	47	-8.0	267,200	29.7	21,480	111	125	72		9.5	339,200	4.63
	60	48	72	51	-9.0	301,500	30.4	21,978	110	125	72		10.5	375,200	5.00
65	53	72	55	-10.1	338,600	31.2	22,587	108	126	72	11.6		414,400	5.38	
70	58	72	59	-11.3	379,100	32.1	23,275	107	126	72	12.8		457,200	5.76	

COOLING	EVAPORATOR LOOP (Water)					ELECTRICAL		CONDENSER LOOP (35% Propylene Glycol)							
	ELT (°F)	Evap. Temp.	Flow (gpm)	LLT (°F)	Delta T (°F)	Cooling (Btu/hr)	Compressor Current (A)*	Input Power (W)	EWT (°F)	Cond. Temp.	Flow (gpm)	LWT (°F)	Delta T (°F)	Heat Rej. (Btu/hr)	EER
COOLING	54	35	72	45	-8.2	294,300	17.7	11,705	50	71	72	60	9.9	333,000	25.1
		35	72	46	-8.0	288,200	18.5	12,353	55	76	72	65	9.8	329,100	23.3
		36	72	46	-7.8	281,900	19.3	13,073	60	82	72	70	9.7	325,300	21.6
		36	72	46	-7.7	276,300	20.3	13,868	65	87	72	75	9.6	322,400	19.9
		37	72	46	-7.5	270,200	21.4	14,760	70	92	72	80	9.5	319,400	18.3
		38	72	46	-7.4	264,500	22.7	15,755	75	97	72	84	9.4	317,100	16.8
		38	72	46	-7.2	258,400	24.1	16,852	80	103	72	89	9.3	314,700	15.3
		39	72	47	-7.0	252,700	25.6	18,054	85	108	72	94	9.3	313,200	14.0
		39	72	47	-6.9	246,400	27.3	19,394	90	113	72	99	9.2	311,400	12.7
40	72	47	-6.7	240,200	29.2	20,872	95	119	72	104	9.2	310,300	11.5		

Performance Tables - W-Series (METRIC UNITS)

W-300-H-X-*D-PP** R454b, 60 Hz, 2 x GSD60137VL (460-3-60)

*Compressor current is for 460-3-60.
Multiply by 2.2 for 208-3-60, by 0.8 for 575-3-60.

METRIC

LOW TEMPERATURE	EVAPORATOR LOOP (50% Propylene Glycol)							ELECTRICAL		CONDENSER LOOP (Water)						
	ELT (°C)	Evap. Temp.	Flow (L/s)	LLT (°C)	Delta T (°C)	Ice Cooling (kW)	COP _c	Compressor Current (A)*	Input Power (W)	EWT (°C)	Cond. Temp.	Flow (L/s)	LWT (°C)	Delta T (°C)	Heating (kW)	COP _H
	-15.0	-19.4	4.5	-16.5	-1.5	24.7	1.93	19.8	14,288	29.4	34.8	4.5	31.4	2.0	37.8	2.64
	-12.2	-16.9	4.5	-13.9	-1.7	28.1	2.12	20.4	14,609		35.0	4.5	31.6	2.2	41.7	2.85
	-9.4	-14.5	4.5	-11.3	-1.9	31.9	2.32	21.0	14,905		35.2	4.5	31.8	2.4	45.9	3.08
	-6.7	-12.1	4.5	-8.9	-2.2	36.0	2.54	21.6	15,181		35.4	4.5	32.1	2.7	50.4	3.32
	-3.9	-9.6	4.5	-6.3	-2.4	40.4	2.77	22.2	15,434		35.6	4.5	32.3	2.9	55.2	3.58
	-1.1	-7.2	4.5	-3.8	-2.7	45.1	3.01	22.7	15,700		35.8	4.5	32.6	3.2	60.4	3.85
	1.7	-4.7	4.5	-1.4	-3.1	50.3	3.26	23.3	15,974		36.1	4.5	32.9	3.5	65.9	4.13
	4.4	-2.3	4.5	1.1	-3.3	55.7	3.51	23.9	16,269		36.3	4.5	33.2	3.8	71.9	4.42

HEATING	EVAPORATOR LOOP (35% Propylene Glycol)							ELECTRICAL		CONDENSER LOOP (Water)						
	ELT (°C)	Evap. Temp.	Flow (L/s)	LLT (°C)	Delta T (°C)	Heat Abs. (kW)	Compressor Current (A)*	Input Power (W)	EWT (°C)	Cond. Temp.	Flow (L/s)	LWT (°C)	Delta T (°C)	Heating (kW)	COP _H	
	-3.9	-9.7	4.5	-6.1	-2.2	37.9	25.0	17,813	40	45.8	4.5	42.9	2.9	55.3	3.11	
	-1.1	-7.1	4.5	-3.6	-2.5	43.7	25.3	18,089		46.2	4.5	43.2	3.2	61.4	3.39	
	1.7	-4.4	4.5	-1.1	-2.8	50.0	25.7	18,353		46.4	4.5	43.6	3.6	68.0	3.70	
	4.4	-1.8	4.5	1.2	-3.2	56.8	26.1	18,652		46.8	4.5	43.9	3.9	75.1	4.02	
	7.2	0.9	4.5	3.5	-3.7	64.5	26.5	18,964		47.1	4.5	44.4	4.4	83.0	4.38	
	10.0	3.6	4.5	5.9	-4.1	72.7	27.0	19,340		47.4	4.5	44.8	4.8	91.7	4.74	
	12.7	6.2	4.5	8.1	-4.6	81.6	27.6	19,767		47.7	4.5	45.3	5.3	101.0	5.11	
	15.5	8.8	4.5	10.3	-5.2	91.5	28.2	20,249		48.0	4.5	45.9	5.9	111.4	5.50	
	18.3	11.5	4.5	12.5	-5.8	102.1	28.9	20,836		48.3	4.5	46.5	6.5	122.6	5.88	
	21.1	14.2	4.5	14.7	-6.4	113.8	29.8	21,499		48.6	4.5	47.2	7.2	134.9	6.28	
	-3.9	-9.6	4.5	-5.8	-1.9	34.4	27.0	19,517	46.1	51.0	4.5	49	2.8	53.5	2.74	
	-1.1	-6.9	4.5	-3.4	-2.3	40.1	27.4	19,782	45.7	51.1	4.5		3.2	59.5	3.01	
	1.7	-4.3	4.5	-0.9	-2.6	46.4	27.8	20,053	45.4	51.2	4.5		3.5	66.0	3.29	
	4.4	-1.6	4.5	1.4	-3.0	53.2	28.2	20,366	45.0	51.4	4.5		3.9	73.2	3.59	
	7.2	1.1	4.5	3.8	-3.4	60.8	28.6	20,687	44.6	51.5	4.5		4.3	81.1	3.92	
	10.0	3.7	4.5	6.1	-3.9	69.2	29.1	21,055	44.1	51.6	4.5		4.8	89.9	4.27	
	12.8	6.4	4.5	8.4	-4.4	78.3	29.7	21,480	43.6	51.7	4.5		5.3	99.4	4.63	
	15.6	9.1	4.5	10.6	-5.0	88.4	30.4	21,978	43.1	51.8	4.5		5.8	110.0	5.00	
	18.3	11.7	4.5	12.7	-5.6	99.2	31.2	22,587	42.4	52.0	4.5		6.4	121.4	5.38	
	21.1	14.4	4.5	14.8	-6.3	111.1	32.1	23,275	41.8	52.1	4.5		7.1	134.0	5.76	

COOLING	EVAPORATOR LOOP (Water)						ELECTRICAL		CONDENSER LOOP (35% Propylene Glycol)						
	ELT (°C)	Evap. Temp.	Flow (L/s)	LLT (°C)	Delta T (°C)	Cooling (kW)	Compressor Current (A)*	Input Power (W)	EWT (°C)	Cond. Temp.	Flow (L/s)	LWT (°C)	Delta T (°C)	Heat Rej. (kW)	COP _c
12	2	4.5	7.4	-4.6	86.3	17.7	11,705	10.0	22	4.5	15.5	5.5	97.6	7.36	
	2	4.5	7.6	-4.4	84.5	18.5	12,353	12.8	25	4.5	18.2	5.4	96.5	6.83	
	2	4.5	7.7	-4.3	82.6	19.3	13,073	15.6	28	4.5	21.0	5.4	95.3	6.33	
	2	4.5	7.7	-4.3	81.0	20.3	13,868	18.3	30	4.5	23.6	5.3	94.5	5.83	
	3	4.5	7.8	-4.2	79.2	21.4	14,760	21.1	33	4.5	26.4	5.3	93.6	5.36	
	3	4.5	7.9	-4.1	77.5	22.7	15,755	23.9	36	4.5	29.1	5.2	92.9	4.92	
	3	4.5	8.0	-4.0	75.7	24.1	16,852	26.7	39	4.5	31.9	5.2	92.2	4.48	
	4	4.5	8.1	-3.9	74.1	25.6	18,054	29.4	42	4.5	34.6	5.2	91.8	4.10	
	4	4.5	8.2	-3.8	72.2	27.3	19,394	32.2	45	4.5	37.3	5.1	91.3	3.72	
4	4.5	8.3	-3.7	70.4	29.2	20,872	35.0	48	4.5	40.1	5.1	90.9	3.37		

WWH-150 to 1000 High Voltage Schematic Diagram

Dual Circuit Scroll / Optional Domestic Hot Water

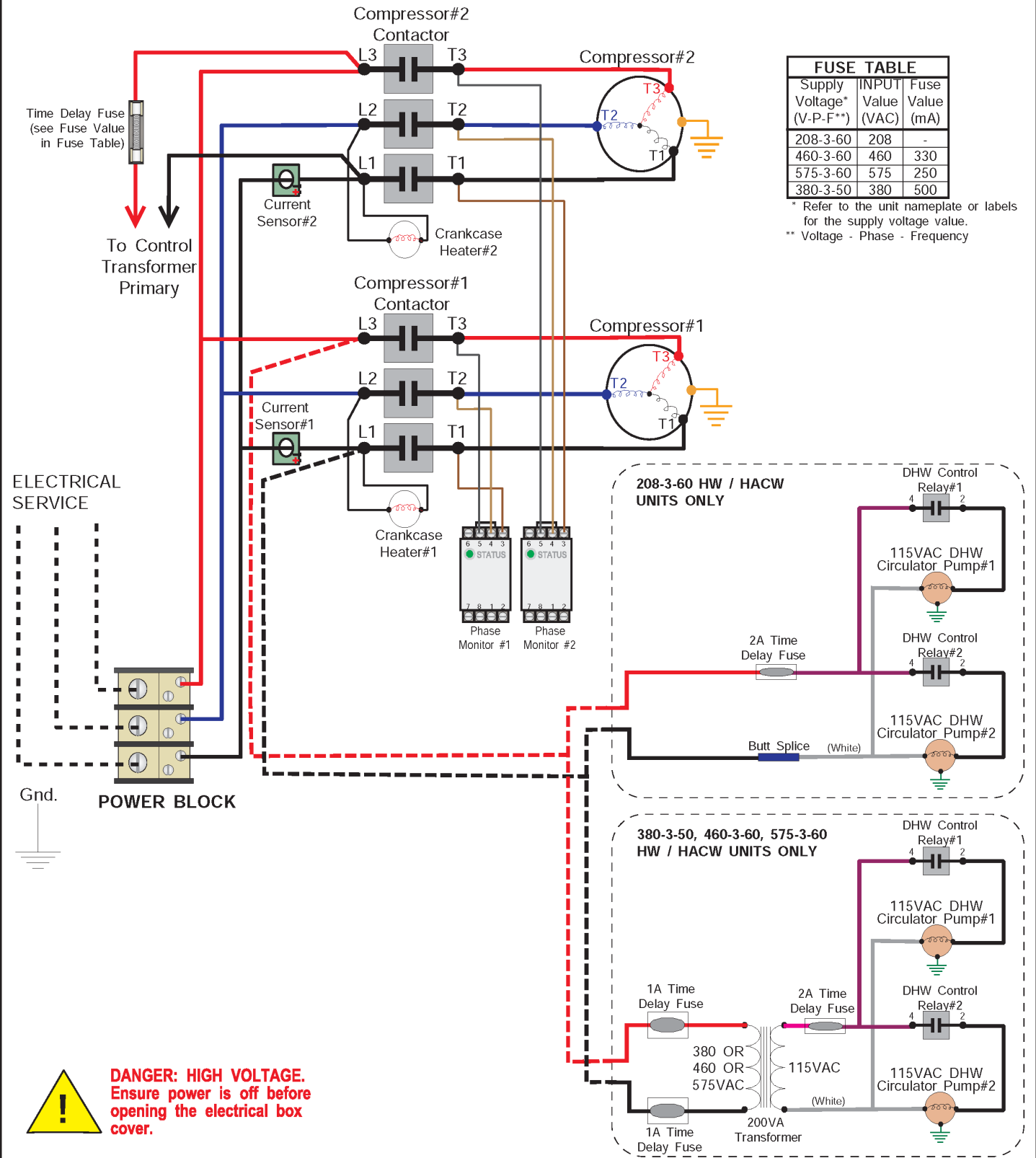

FUSE TABLE		
Supply Voltage* (V-P-F**)	INPUT Value (VAC)	Fuse Value (mA)
208-3-60	208	-
460-3-60	460	330
575-3-60	575	250
380-3-50	380	500

* Refer to the unit nameplate or labels for the supply voltage value.
 ** Voltage - Phase - Frequency



DANGER: HIGH VOLTAGE.
 Ensure power is off before opening the electrical box cover.

02	ISSUE 03	D. RHEAULT	D. RHEAULT	24-Jun-2022	Drawn By Chris Geddes	Date 18-Oct-2012	MARITIME GEOTHERMAL LTD. 170 Plantation Rd. Petitcodiac, NB E4Z 6H4
02	ISSUE 02	D. RHEAULT	D. RHEAULT	15-Mar-2022	Checked By Chris Geddes	Date 18-Oct-2012	
02	Reformatted	D. RHEAULT	D. RHEAULT	01-Nov-2017	Approved By (ENG) Chris Geddes	Date 18-Oct-2012	
01	Initial Release	C. GEDDES	C. GEDDES	18-Oct-2012	Approved By (MFG)	Date	
REV	ECO #	IMPL BY	APVD BY	DATE	Approved By	Date	Drawing Name WWH-150 to WWH-1000-H***D-PP High Voltage Schematic Diagram
					Size A	Drawing Number 001717SCH	Drawing Rev 02(13) SHEET 1 of 1

W/WH-150 to 1000 Low Voltage Schematic Diagram - Dual Circuit / Dual Compressor

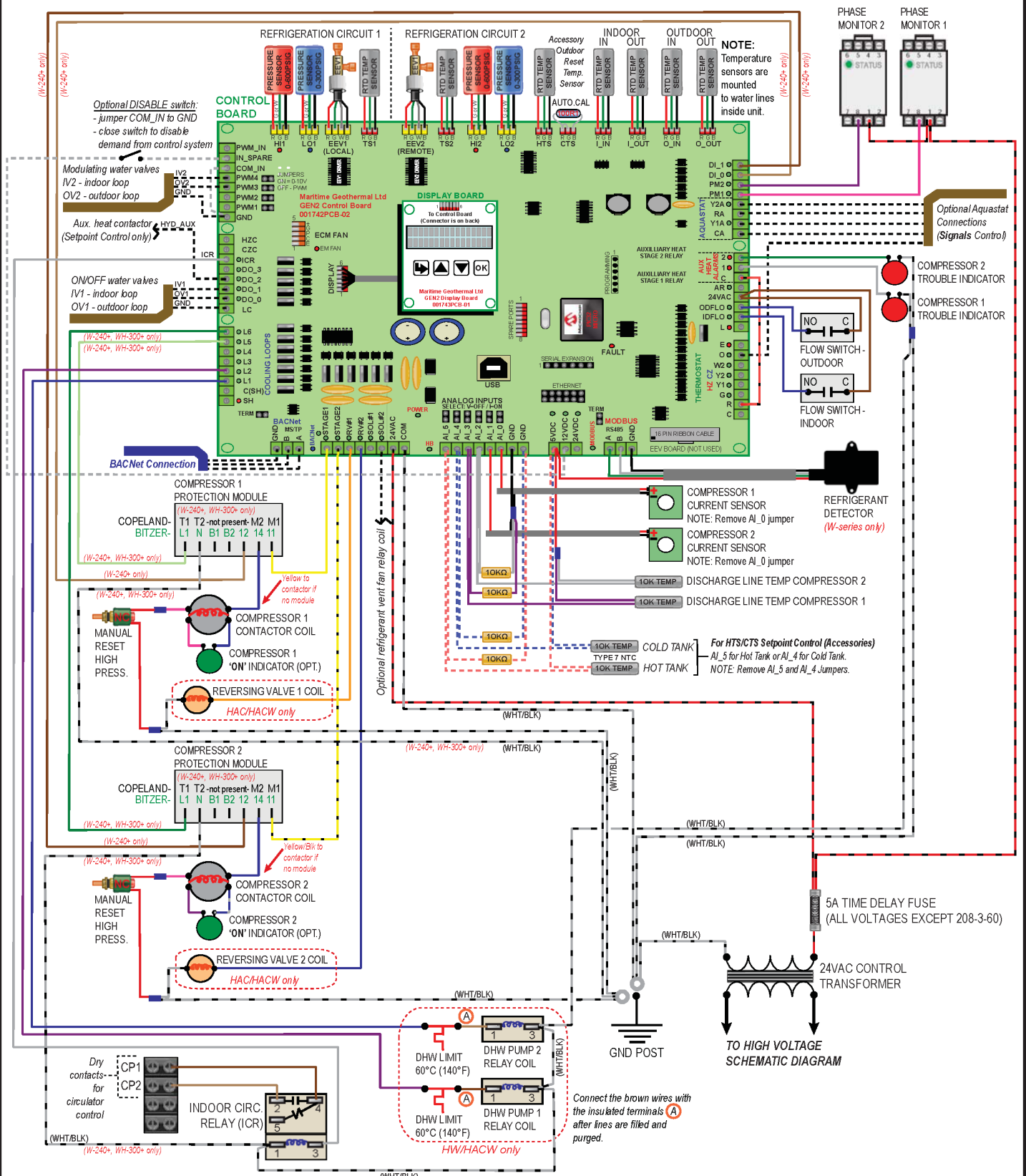

01 Initial Release		D. RHEAULT	D. RHEAULT	27-SEP-2024	Drawn By D. RHEAULT Date 27-SEP-2024	MARITIME GEOTHERMAL LTD. P.O. Box 2555 170 Plantation Rd. Pettitcodiac, NB CANADA E4Z 6H4	
REV	ECO#	IMPL BY	APVD BY	DATE	Checked By D. RHEAULT Date 27-SEP-2024		Drawing Name W/WH-150~1000-H***-X/Y-*D-PP Low Voltage Schematic Diagram
					Eng. Approved By Date		Drawing Number 002752SCH
					Mfg. Approved By Date		Drawing Rev 01
					Approved By Date	Sheet 1 / 1	

W/WH-150 to 1000 Electrical Box Diagram

FUSE TABLE ***	
Supply Voltage	Fuse Value*
208-3-60	-----
460-3-60	330mA
575-3-60	250mA
380-3-50	500mA

CONTROL CONNECTIONS (HARDWIRED OPTION)
 Y2A(Compressor #2) RA(24VAC)
 Y1A(Compressor #1) CA(Common) O(Cooling)

- Use PC App or LCD menus to select 1 of 3 Control Methods:**
- BACnet
 - Hardwired (24VAC signals)
 - Setpoint Control (internal)

1. BACnet (MS/TP RS-485)

Use twisted pair shielded-conductor cable.
 A - Communication
 B - Communication
 GND - Ground
 SYSTEM_Y1A: Stage 1 (compr.1)
 SYSTEM_Y2A: Stage 2 (compr.2)
 SYSTEM_O: Htg/Cooling Mode (active in cooling)

2. Hardwired (24VAC)

Use an 18-4 or 18-5 cable.
 C - 24VAC Common
 R - 24VAC Hot
 Y1A - Stage 1 (Compressor 1)
 Y2A - Stage 2 (Compressor 2)
 O - Heating/Cooling Mode (active for cooling mode)
 A dry contact from "R" to "Y1A" will start compressor #1.
 A dry contact from "R" to "Y2A" will start compressor #2.
 A dry contact from "R" to "O" will activate cooling mode (for both compressors).

3. Setpoint Control

Unit will be controlled by internal water line temperature sensors. See manual for setup instructions.

DANGER: HIGH VOLTAGE. Ensure power is off before opening the electrical box cover.

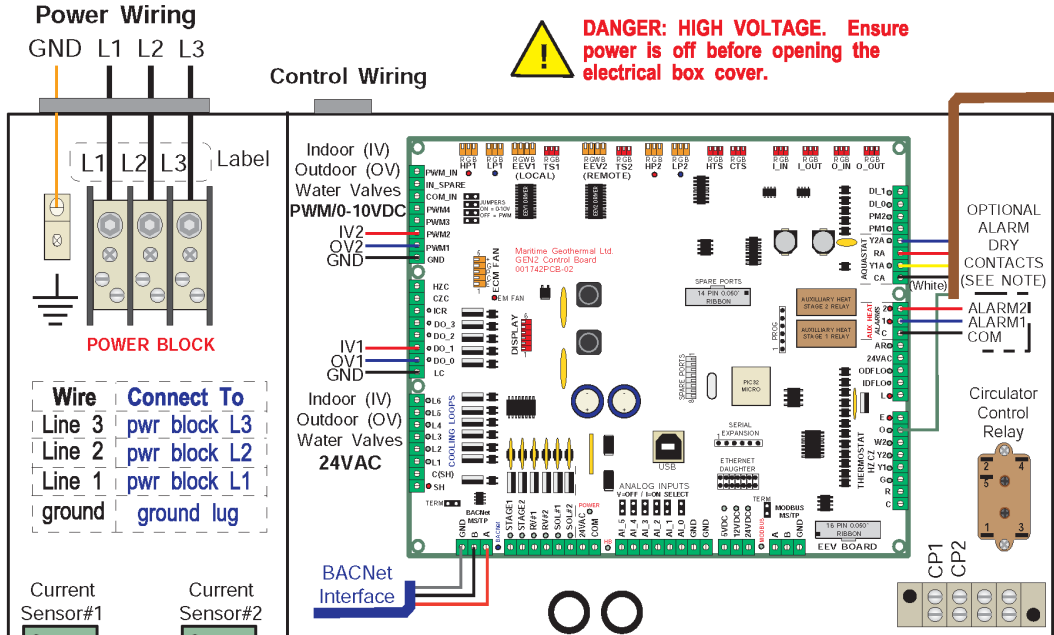

Wire	Connect To
Line 3	pwr block L3
Line 2	pwr block L2
Line 1	pwr block L1
ground	ground lug

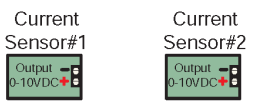

380/460/575VAC only. See Fuse Table for fuse size.
FOR 208-3-60VAC: Set phase monitor adjust knobs (if present) as below.

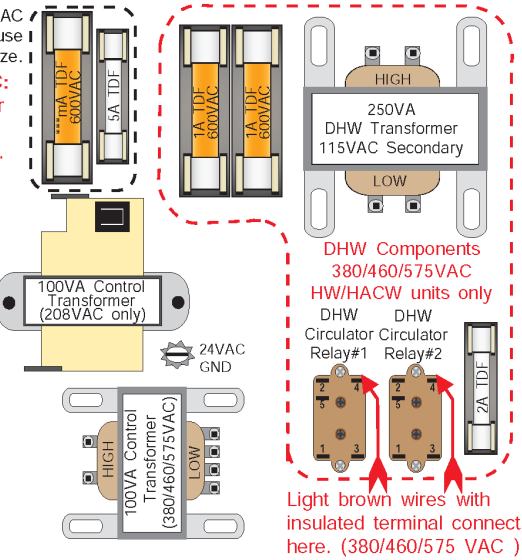
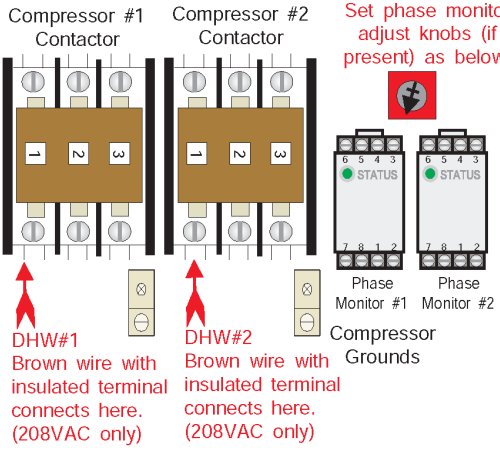

DHW NOTE: If the heat pump is to be operated without the hot water circulators connected to the water tank and flooded with water, remove the brown (or light brown) wire with the insulated terminal from the location(s) shown in the diagram above. **The pumps are water lubricated and must not be run dry.**

IMPORTANT NOTES:

- **3 PHASE SCROLL COMPRESSORS** must rotate in the proper direction. After the initial connection, if the phase protection module(s) indicate a fault on power up, turn the power off and reverse the L1 and L2 supply leads. Turn the power on and clear the fault(s).
- **IMPORTANT:** Ensure sufficient antifreeze concentration is used and correctly set in control board via the PC App, so that the correct low pressure cutout value is implemented to prevent freezing conditions. Failure to do so could cause the heat exchanger to freeze and rupture, voiding the warranty.

- Stages Y1A & Y2A are completely independent (unlike with residential "Ultratech" compressors). Each may be used at any time.
- **Anti-short cycle timer** of 5 minutes exists for each compressor.
- **Alarm1 and Alarm2** signals are dry contacts (NO). Connect the signal source to COM. Alarm1 is for stage 1 (Y1A) and Alarm2 is for stage 2 (Y2A). **MAX 1amp @ 24VAC**
- **CP1 and CP2** are a dry contact that can be used to turn on circulator pumps when either compressor starts. In Setpoint Control mode, it is indoor circulators only (sampling). **MAX 5amps @ 24VAC**
- **Water Valve:** 24VAC is present across OV1/IV1 and GND to power an external ON/OFF water valve when either compressor starts. Modulating water valves can be connected between OV2/IV2 and GND. **MAX 1amp @ 24VAC**

REV	ECO #	IMPL BY	APVD BY	DATE	Drawn By	Date	Checked By	Date	Approved By	Date	Approved By	Date	Size	Drawing Number	Drawing Rev	SHEET
02	ISSUE 03	D. RHEAULT	D. RHEAULT	24-Jun-2022	Chris Geddes	18-Oct-2012	Chris Geddes	18-Oct-2012	Chris Geddes	18-Oct-2012	Chris Geddes	18-Oct-2012	A	001719ELB	02(i3)	1 of 1
02	ISSUE 02	D. RHEAULT	D. RHEAULT	15-Mar-2022	Chris Geddes	18-Oct-2012	Chris Geddes	18-Oct-2012	Chris Geddes	18-Oct-2012	Chris Geddes	18-Oct-2012				
02	Reformatted	D. RHEAULT	D. RHEAULT	01-Nov-2017	Chris Geddes	18-Oct-2012	Chris Geddes	18-Oct-2012	Chris Geddes	18-Oct-2012	Chris Geddes	18-Oct-2012				
01	Initial Release	C. GEDDES	C. GEDDES	18-Oct-2012	Chris Geddes	18-Oct-2012	Chris Geddes	18-Oct-2012	Chris Geddes	18-Oct-2012	Chris Geddes	18-Oct-2012				

W/WH-150 to 1000-H/HW Refrigeration Circuit [No Reversing Valve]

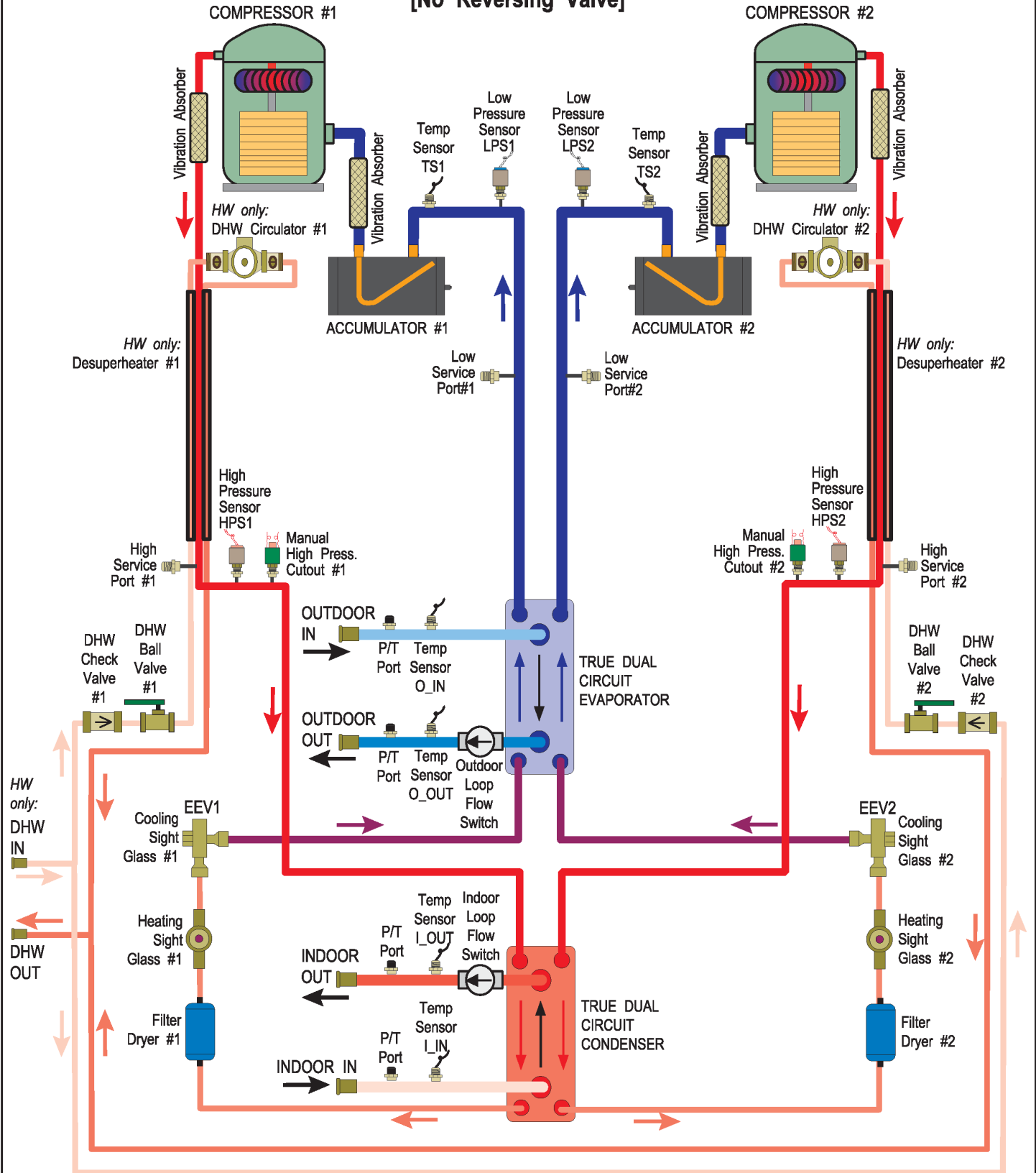

					Drawn By Chris Geddes Date 23-Oct-2012	MARITIME GEOTHERMAL LTD. 170 Plantation Rd. Petitcodiac, NB E4Z 6H4
					Checked By Chris Geddes Date 23-Oct-2012	
01(i2)	ISSUE 02	D. RHEAULT	D. RHEAULT	1-Jun-2022	Approved By (ENG) Chris Geddes Date 23-Oct-2012	
01	Initial Release	C. GEDDES	C. GEDDES	23-Oct-2012	Approved By (MFG) Date	
REV	ECO #	IMPL BY	APVD BY	DATE	Approved By	Date
						Drawing Name W/WH-150 to 1000-H(W) Refrigeration Circuit Diagram
						Size A
						Drawing Number 001720RCD
						Drawing Rev 01(i2)
						SHEET 1 of 1

W/WH-150 to 1000-HAC/HACW Refrigeration Circuit

HEATING MODE

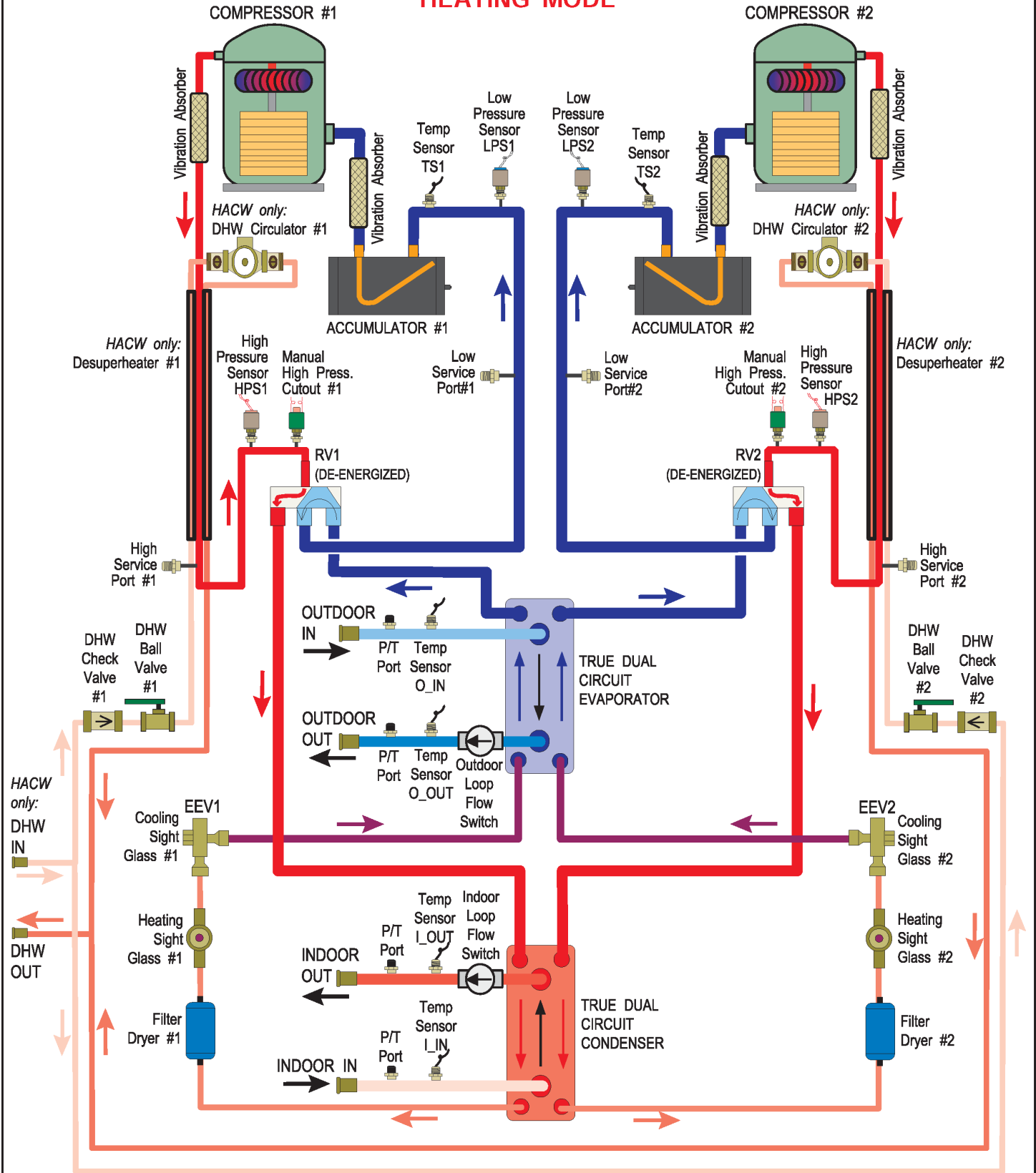

					Drawn By Chris Geddes	Date 23-Oct-2012	MARITIME GEOTHERMAL LTD. 170 Plantation Rd. Petitcodiac, NB E4Z 6H4
					Checked By Chris Geddes	Date 23-Oct-2012	
					Approved By Chris Geddes (ENG)	Date 23-Oct-2012	
					Approved By (MFG)	Date	
02	000303	D. RHEAULT	D. RHEAULT	1-Jun-2022	Drawing Name W/WH-150 to 1000-HAC(W)		Drawing Rev SHEET
01	Initial Release	C. GEDDES	C. GEDDES	23-Oct-2012	Refrigeration Circuit Diagram - Heating Mode		
REV	ECO #	IMPL BY	APVD BY	DATE	Size A	Drawing Number 001721RCD	Drawing Rev 02
							1 of 1

W/WH-150 to 1000-HAC/HACW Refrigeration Circuit

COOLING MODE

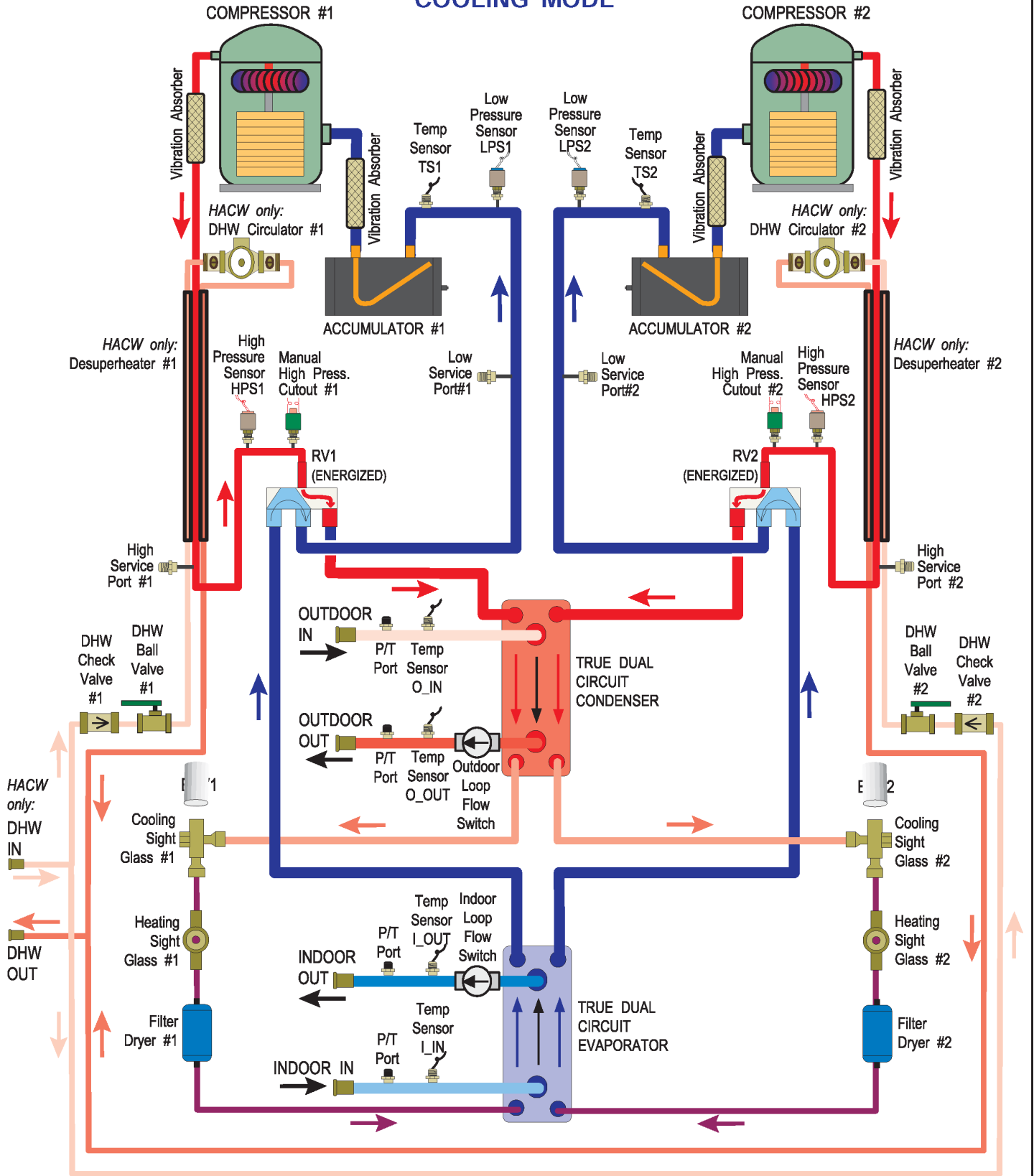

					Drawn By Chris Geddes	Date 23-Oct-2012	MARITIME GEOTHERMAL LTD. 170 Plantation Rd. Petitcodiac, NB E4Z 6H4
					Checked By Chris Geddes	Date 23-Oct-2012	
02	000303	D. RHEAULT	D. RHEAULT	1-Jun-2022	Approved By Chris Geddes	(ENG) Date 23-Oct-2012	Drawing Name W/WH-150 to 1000-HAC(W) Refrigeration Circuit Diagram - Cooling Mode
01	Initial Release	C. GEDDES	C. GEDDES	23-Oct-2012	Approved By (MFG)	Date	Size A
REV	ECO #	IMPL BY	APVD BY	DATE	Approved By	Date	Drawing Number 001722RCD
							Drawing Rev 02
							SHEET 1 of 1

BACnet Interface

The BACnet interface is an **MS/TP** connection via RS-485 twisted pair. BACnet **IP** is not available.
Recommended wire: 22-24 AWG single twisted pair, 100-120 Ohms impedance, 17pF/ft or lower capacitance, with braided or aluminum foil shield, such as Belden 9841 or 89841.

The connector on the control board is a three wire removable screw connector. The signals are as follows:

- A: Communications line (+) (right pin)
- B: Communications line (-) (middle pin)
- C: Ground connection (left pin)

If connecting multiple units to one RS-485 connection point, connect the signal cable from the master building controller to the first unit. Connect the second unit to the first unit (in same connector), connect the third unit to the second unit, and so on until all units are connected (daisy-chain). Remove the TERM jumper (located just above the BACnet connector on control board) from all units except the last one. The shield ground should be connected only to the GND pin of the unit for single unit installations. For multiple units, the shield ground should only be connected to the GND pin of the last unit. The shield grounds for intermediate units should be connected together. The shield ground should be left unconnected at the building controller end for all cases.

Vendor: Maritime Geothermal Ltd.
Vendor ID: 260
Model Name: MGT GEN2 Control Board

The following parameters can be set via the PC App's *Configuration Window*:

- 1) **Baud rate**
9600, 19200, 38400, or 76800
- 2) **MAC address**
Maximum value is 125.
- 3) **Instance number**
Maximum value is 4194303.

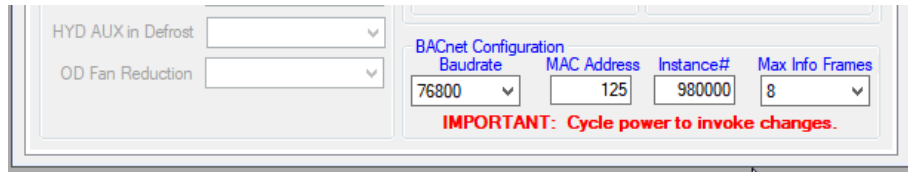

The BACnet parameter **Max_Master** has a fixed value of **127** in this device.

BACnet data is available regardless of the selected control method. In order to control the unit via the BACnet interface, set **Control Source** to **BACnet** either by using the PC App's configuration window or the LCD menus.

For tables listing BACnet objects, refer to **Application, Installation, and Service Manual**.

Engineering Guide Specifications

General

The water-to-water heat pump shall be a single packaged dual refrigeration circuit heating / cooling unit. The unit shall be listed by a nationally recognized testing laboratory (NRTL), such as UL, CSA, TUV, or ETL. The unit shall be rated in accordance with applicable standards of the Air Conditioning, Heating, and Refrigeration Institute / International Standards Organization (AHRI/ISO) and/or Canadian Standards Association (CSA). The liquid source water to water heat pump, as manufactured by Maritime Geothermal Ltd. of Petitcodiac, New Brunswick, Canada shall be designed to operate correctly within liquid temperature ranges specified on the "Minimum and Maximum Operating Temperatures" page of this engineering specification document.

Factory Quality

Each unit shall be run tested at the factory with water circulating in both indoor and outdoor loops. Quality control system checks shall include: computerized nitrogen pressurized leak test, evacuation of refrigeration circuit to sustained vacuum, accurate system charge, detailed heating and cooling mode tests, and quality cross check all operational and test conditions to pass/fail criteria. Units tested without water flow are not acceptable. The units shall be warranted by the manufacturer against defects in materials and workmanship in accordance with the warranty section at the end of this document. Optional extended factory warranty coverage may be available.

Cabinet

Each unit shall be constructed with a heavy duty standalone frame, and may optionally be enclosed in a sheet metal cabinet. Frame shall be constructed of powder coated galvanized sheet metal of minimum 11 gauge. Cabinet shall be constructed of powder coated galvanized sheet metal of minimum 16 gauge. Sheet metal gauge shall be higher where structurally required. Design and construction of cabinet shall be such that it is rigid and passes the CSA/UL Loading Test requirements (200 lb roof test and 25 lb guard test). All panels shall be lined with minimum 1 inch [25.4 mm] thick acoustic type glass fiber insulation. All insulation shall meet the fire retardant provisions of NFPA 90A. This material shall also provide acoustical benefit. Any enclosure must have a minimum of six access panels for serviceability of the compressor compartment. Enclosures having fewer than six access panels to compressor/heat exchangers/expansion device/refrigerant piping shall not be acceptable. The electrical box shall have separate holes and knockouts for entrance of line voltage and low voltage control wiring. All factory-installed wiring passing through factory knockouts and openings shall be protected from sheet metal edges at openings by plastic grommets.

Refrigerant Circuit

All units shall contain two separate sealed refrigerant circuits, each containing a hermetic motor scroll compressor, one electronic expansion valve, factory installed high and low pressure sensors, service ports, solid core filter-dryer, sight glass, reversing valve (for reversing units), and suction accumulator. Refrigerant circuits shall share true dual circuit brazed plate heat exchangers.

Refrigerant used shall have a global warming potential (GWP) of less than 500. A refrigerant leak detector shall be factory installed.

Compressors shall be specified for heat pump duty with internal isolation consisting of rubber vibration isolators. Compressor motors shall have internal overload protection. Compressor shall be mechanically isolated from rest of refrigerant circuit by suction and discharge vibration absorbers. Compressor shall be equipped with a crankcase/sump heater to prevent liquid refrigerant migration during the off cycle and subsequent flooded starts.

The water to refrigerant heat exchangers shall be of a stainless steel brazed plate design, designed and certified for 650 psig [4480 kPa] working pressure on the refrigerant side and 650 psig [4480 kPa] on the water side. Heat exchangers shall be insulated over all of their outside surface with minimum 3/8" thick closed cell insulation. Insulation consisting of 1/8" closed-cell insulating tape shall not be acceptable.

The electronic expansion valves shall be of stepper-motor rather than pulsing type, and shall provide proper superheat control over the unit's operating range with minimal deviation from superheat setpoint. The valves shall be controlled by electronic superheat controller(s) which provide operator-adjustable superheat and real-time LED/LCD display of current superheat. Superheat shall be determined through the suction pressure-temperature method. Externally mounted pressure controlled water regulating flow valves or thermostatic expansion valves (TXV's) in place of electronic expansion valves are not acceptable.

The suction accumulators shall be insulated with minimum 3/8" thick closed cell insulation to prevent condensation. The accumulator's internal oil return port shall be sized properly for the unit's operating range. To ensure proper oil return, suction accumulator shall not be 'oversized'.

Piping and Connections

The unit shall have two sets of primary water in and water out connections (outdoor and indoor). The primary connection type shall be stainless steel pipe for Victaulic connection.

All internal water and refrigerant piping shall be insulated with minimum 3/8" thick closed cell insulation. Insulation consisting of 1/8" closed-cell insulating tape shall not be acceptable.

Electrical

Controls and safety devices shall be factory wired and mounted within the unit. Controls shall include 24 volt alternating current (24VAC) activated compressor contactors, reversing valves, and 24VAC 100VA transformer with built in circuit breaker or fused on both primary and secondary sides. Units shall be name-plated for use with time delay fuses or circuit breakers. Unit controls shall be 24VAC and provide heating or cooling as required by the remote thermostat or controller. 3-phase protection shall be present in each unit to protect the compressor against loss of phase and reverse rotation. 3-phase protection shall be factory installed. Unit shall have dry contacts for controlling loop circulating pumps via an external 24VAC contactor. Unit shall provide remote fault indication to the control system via serial communication and fault messages on front panel LCD display.

Unit Control

The control system shall have the following features:

1. Anti-short cycle time delay on compressor operation. Time delay shall be a minimum of 5 minutes, for both thermostat demand and safety control reset starts. An override shall be provided to disable this delay for unit commissioning and testing purposes.
2. Random compressor start delay of 0-120 seconds on unit power up to facilitate starting multiple units after a power failure.
3. Flow switch on outdoor loop, and also on indoor loop for reversing units.
4. Compressor shutdown for high or low refrigerant pressures, low flow conditions and for phase protection faults.
5. Automatic intelligent reset: unit shall automatically restart 5 minutes after trip if the fault has cleared. Should a fault reoccur 3 times sequentially then permanent lockout shall occur, requiring cycling of the power to the unit in order to reset.
6. Manual reset high pressure in case of electronic board failure.
7. The low pressure shall not be monitored for the first 90 seconds after a compressor start to prevent nuisance safety trips.
8. 2 x 16 backlit Liquid Crystal Display (LCD) and four buttons for limited data access. Unit may be configured for stand alone operation with optional temperature sensor(s)
9. Universal Serial Bus (USB) port for full data access and diagnostic information, including real-time charting and data-logging

Maritime Geothermal works continually to improve its products. As a result, the design and specifications of any product may be changed without notice. Please contact Maritime Geothermal at 1-506-756-8135 or visit www.nordicghp.com for latest design and specifications. Purchaser's approval of this data set signifies that the equipment is acceptable under the provisions of the job specification. Statements and other information contained herein are not express warranties and do not form the basis of any commercial contract or other agreement between any parties, but are merely Maritime Geothermal's statement of opinion regarding its products.

Warranty: W/WH-Commercial Series

COMMERCIAL LIMITED EXPRESS WARRANTY

Unless a statement is specifically identified as a warranty, statements made by Maritime Geothermal Ltd. ("MG") or its representatives relating to MG's products, whether oral, written or contained in any sales literature, catalogue or agreement, are not express warranties and do not form a part of the basis of the bargain, but are merely MG's opinion or commendation of MG's products.

SET FORTH HERE IS THE ONLY EXPRESS WARRANTY THAT APPLIES TO MG'S PRODUCTS. MG MAKES NO WARRANTY AGAINST LATENT DEFECTS. MG MAKES NO WARRANTY OF MERCHANTABILITY OF THE GOODS OR OF THE FITNESS OF THE GOODS FOR ANY PARTICULAR PURPOSE.

LIMITED EXPRESS COMMERCIAL WARRANTY - PARTS

MG warrants its Commercial Class products, purchased and retained in the United States of America and Canada, to be free from defects in material and workmanship under normal use and maintenance as follows:

- (1) Heat pumps / chillers built or sold by MG for one (1) year from the Warranty Inception Date (as defined below).
- (2) Compressors of above units for five (5) years from the Warranty Inception Date (as defined below).
- (3) Other accessories, when purchased separately, for (1) year from the date of shipment from MG.

The "Warranty Inception Date" shall be the date of original unit installation, as per the date on the installation Startup Record; or sixty (60) days from date of unit shipment from MG, whichever comes first.

To make a claim under this warranty, parts must be returned to MG in Petitcodiac, New Brunswick, freight prepaid, no later than ninety (90) days after the date of the failure of the part. If MG determines the part to be defective and within MG's Limited Express Commercial Warranty, MG shall, when such part has been either replaced or repaired, return such to a factory recognized distributor, dealer or service organization, freight prepaid. The warranty on any part repaired or replaced under warranty expires at the end of the original warranty period.

LIMITED EXPRESS COMMERCIAL WARRANTY - LABOUR

MARITIME GEOTHERMAL LTD. will not be responsible for any consequential damages or labour costs incurred.

This warranty does not cover and does not apply to:

- (1) Air filters, fuses, refrigerant, fluids, oil.
- (2) Products relocated after initial installation.
- (3) Any portion or component of any system that is not supplied by MG, regardless of the cause of the failure of such portion or component.
- (4) Products on which the unit identification tags or labels have been removed or defaced.
- (5) Products on which payment to MG, or to the owner's seller or installing contractor, is in default.
- (6) Products subjected to improper or inadequate installation, including but not limited to:
 - Indoor or outdoor loop flow lower than listed in engineering specification or as expressly approved by MARITIME GEOTHERMAL LTD.
 - Operating the heat pump either manually or with automated controls so that the unit is forced to function outside its normal operating range
 - Disabling of safety controls
 - Insufficient loop antifreeze concentration for loop temperature, or antifreeze concentration incorrectly set in control board
 - Fouled heat exchangers due to poor water quality
 - Failure to use strainers or clean them regularly
 - Impact or physical damage sustained by the heat pump
 - Poor refrigeration maintenance practices, including brazing without nitrogen flow, or using wrong braze/flux
 - Incorrect voltage or missing phase supplied to unit
 - Unit modified electrically or mechanically from factory supplied condition
 - Water quality outside of recommended limits (e.g. salinity or pH)
 - Unit not mounted with supplied anti-vibration grommets when specified for use
 - Corrosion damage due to corrosive ambient environment
 - Failure due to excessive cycling caused by improper mechanical setup or improperly programmed external controller
 - Physical loads or pressures placed on unit from external equipment
- (7) Mold, fungus or bacteria damage
- (8) Corrosion or abrasion of the product.
- (9) Products supplied by others.
- (10) Electricity or fuel, or any increases or unrealized savings in same, for any reason whatsoever.

MG is not responsible for:

- (1) The costs of fluids, refrigerant or system components **supplied by others**, or associated **labour** to repair or replace the same, which is incurred as a result of a defective part covered by MG's Limited Commercial Warranty.
- (2) The costs of **labour**, refrigerant, materials, or service incurred in diagnosis and removal of defective part, or in obtaining and replacing the new or repaired part.
- (3) Transportation costs of the defective part from the installation site to MG, or of the return of that part if warranty coverage declined.
- (4) The costs of normal maintenance.

MG'S LIABILITY UNDER THE TERMS OF THIS LIMITED WARRANTY SHALL APPLY ONLY TO THE MG UNITS REGISTERED WITH MG THAT BEAR THE MODEL AND SERIAL NUMBERS STATED ON THE INSTALLATION START UP RECORD, AND MG SHALL NOT, IN ANY EVENT, BE LIABLE UNDER THE TERMS OF THIS LIMITED WARRANTY UNLESS THIS INSTALLATION START UP RECORD HAS BEEN ENDORSED BY OWNER & DEALER/INSTALLER AND RECEIVED BY MG LIMITED WITHIN 90 DAYS OF START UP.

Limitation: This Limited Express Commercial Warranty is given in lieu of all other warranties. If, notwithstanding the disclaimers contained herein, it is determined that other warranties exist, any such express warranty, including without limitation any express warranties or any implied warranties of fitness for particular purpose and merchantability, shall be limited to the duration of the Limited Express Commercial Warranty.

LIMITATION OF REMEDIES

In the event of a breach of the Limited Express Commercial Warranty, MG will only be obligated at MG's option to repair the failed part or unit, or to furnish a new or rebuilt part or unit in exchange for the part or unit which has failed. If after written notice to MG's factory in Petitcodiac, New Brunswick of each defect, malfunction or other failure, and a reasonable number of attempts by MG to correct the defect, malfunction or other failure, and the remedy fails of its essential purpose, MG shall refund the purchase price paid to MG in exchange for the return of the sold good(s). Said refund shall be the maximum liability of MG. **THIS REMEDY IS THE SOLE AND EXCLUSIVE REMEDY OF THE BUYER OR PURCHASER AGAINST MG FOR BREACH OF CONTRACT, FOR THE BREACH OF ANY WARRANTY OR FOR MG'S NEGLIGENCE OR IN STRICT LIABILITY.**

LIMITATION OF LIABILITY

MG shall have no liability for any damages if MG's performance is delayed for any reason or is prevented to any extent by any event such as, but not limited to: any war, civil unrest, government restrictions or restraints, strikes, or work stoppages, fire, flood, accident, shortages of transportation, fuel, material, or labour, acts of God or any other reason beyond the sole control of MG. **MG EXPRESSLY DISCLAIMS AND EXCLUDES ANY LIABILITY FOR CONSEQUENTIAL OR INCIDENTAL DAMAGE IN CONTRACT, FOR BREACH OF ANY EXPRESS OR IMPLIED WARRANTY, OR IN TORT, WHETHER FOR MG'S NEGLIGENCE OR AS STRICT LIABILITY.**

OBTAINING WARRANTY PERFORMANCE

Normally, the dealer or service organization who installed the products will provide warranty performance for the owner. Should the installer be unavailable, contact any MG recognized distributor, dealer or service organization. If assistance is required in obtaining warranty performance, write or call Maritime Geothermal Ltd.

NOTE: Some states or Canadian provinces do not allow limitations on how long an implied warranty lasts, or the limitation or exclusions of consequential or incidental damages, so the foregoing exclusions and limitations may not apply to you. This warranty gives you specific legal rights, and you may also have other rights which vary from state to state and from Canadian province to Canadian province.