

Engineering Specification

W-100-H-X-*S-** (Non-reversing)

W-100-HAC-X-*S-** (Reversing)

W-100-HW-X-*S-** (Non-reversing, with desuperheater)

W-100-HACW-X-*S-** (Reversing, with desuperheater)

Commercial Water to Water Heat Pump
Single Compressor, Coaxial Coils, R454b, 60 Hz
Nominal Size 9 Ton

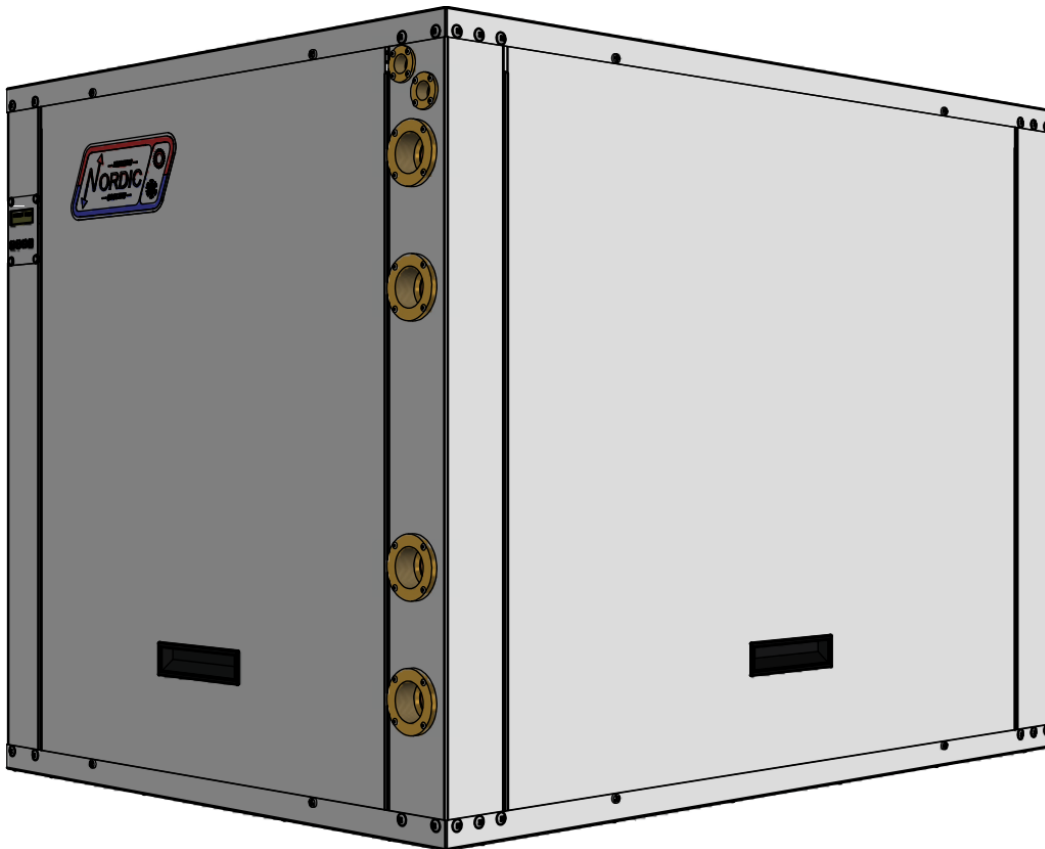

Maritime Geothermal Ltd.
P.O. Box 2555, 170 Plantation Road
Petitcodiac, NB E4Z 6H4
(506) 756-8135

info@nordicghp.com
www.nordicghp.com
002772SPC-01

Model Nomenclature

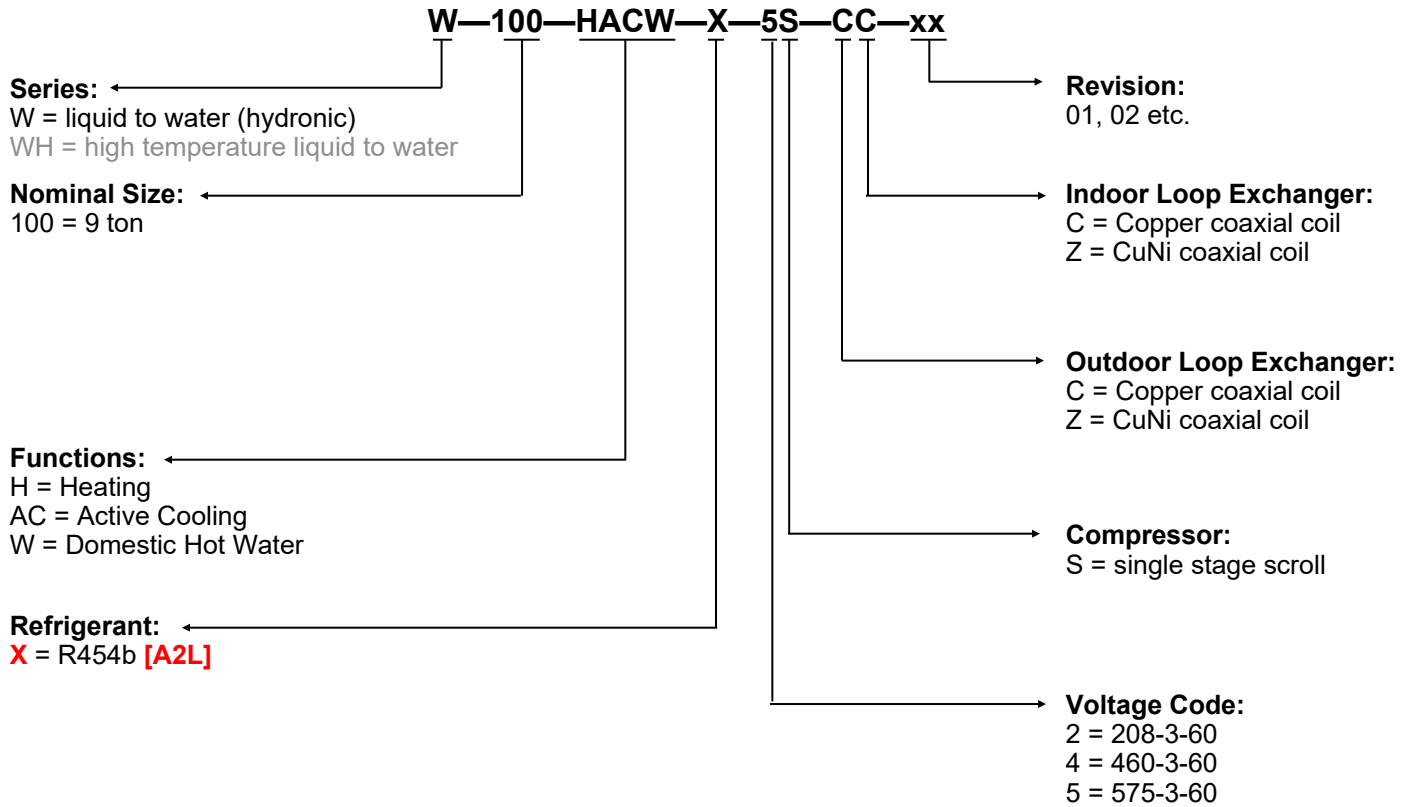

APPLICATION TABLE										
MODEL	FUNCTION	REFRIGERANT	VOLTAGE	COMPR.	OUTDOOR COIL	INDOOR COIL	REVISIONS			
W-100	H HAC HACW HW	X	2 4 5	S	C Z	C Z	01			

Maritime Geothermal Ltd. has a continuous improvement policy and reserves the right to modify specification data at any time without prior notice .

Design Features

- R454b refrigerant (GWP=466) is climate change-friendly. Note that R454b has an **A2L** classification.
- Indoor loop water heating to 130°F / 54°C, at typical geothermal ground loop temperatures
- TUV certified for safety (UL/CSA equivalent)
- Satin galvanized steel cabinet with powder coat finish
- Acoustically insulated (1/2" & 1" thick)
- All pipe connections located on same side
- Access panels on all four sides, serviceable from two; swing out electrical box for compressor access
- Refrigeration service ports located inside unit (1/4" Schrader)
- Insulated coaxial heat exchangers and piping, available in copper or cupro-nickel (CuNi)
- 1-1/4" brass FNPT fittings for loop connections
- Dry contacts to control outdoor and indoor circulator pump power
- Scroll compressor
- Dual-grommet-mounted compressor for reduced noise and vibration
- Suction line accumulator
- Liquid line filter-dryer & sight glass
- 4-way reversing valve (*-HAC and -HACW models*)
- Available desuperheater for passive domestic hot water heating (*-HW and -HACW models*)
- Electronic Expansion Valve (EEV)
- Refrigerant high and low pressure sensors, manual reset high pressure control
- Suction line temperature sensor
- Temperature sensors on all 4 water lines
- Control transformer with resettable breaker or fuse protection
- Advanced control board with BACNet interface for remote operation and data access including all sensor data and alarm conditions, PWM outputs (or 0-10VDC), configurable analog inputs (0-5VDC or 4-20mA) with onboard 5VDC, 12VDC and 24VDC power supplies
- USB port for complete data access including real-time charting, data logging, and diagnostic functionality with manual override operation
- 2 x 16 LCD display for control and data access
- Onboard water temperature control, with outdoor reset (requires outdoor temperature sensor accessory)
- Random start on power up (0-2 minutes)
- 24VAC and 0-10VDC output for external pump / water valve control (24VAC 500mA max)
- Compressor current sensor

Available Accessories

- Anti-vibration pad for under unit
- Compressor sound jacket
- 1-1/4" solenoid water valve
- Outdoor temperature sensor with enclosure, for outdoor reset functionality
- Tank temperature sensor(s) for standalone configuration

Design Features

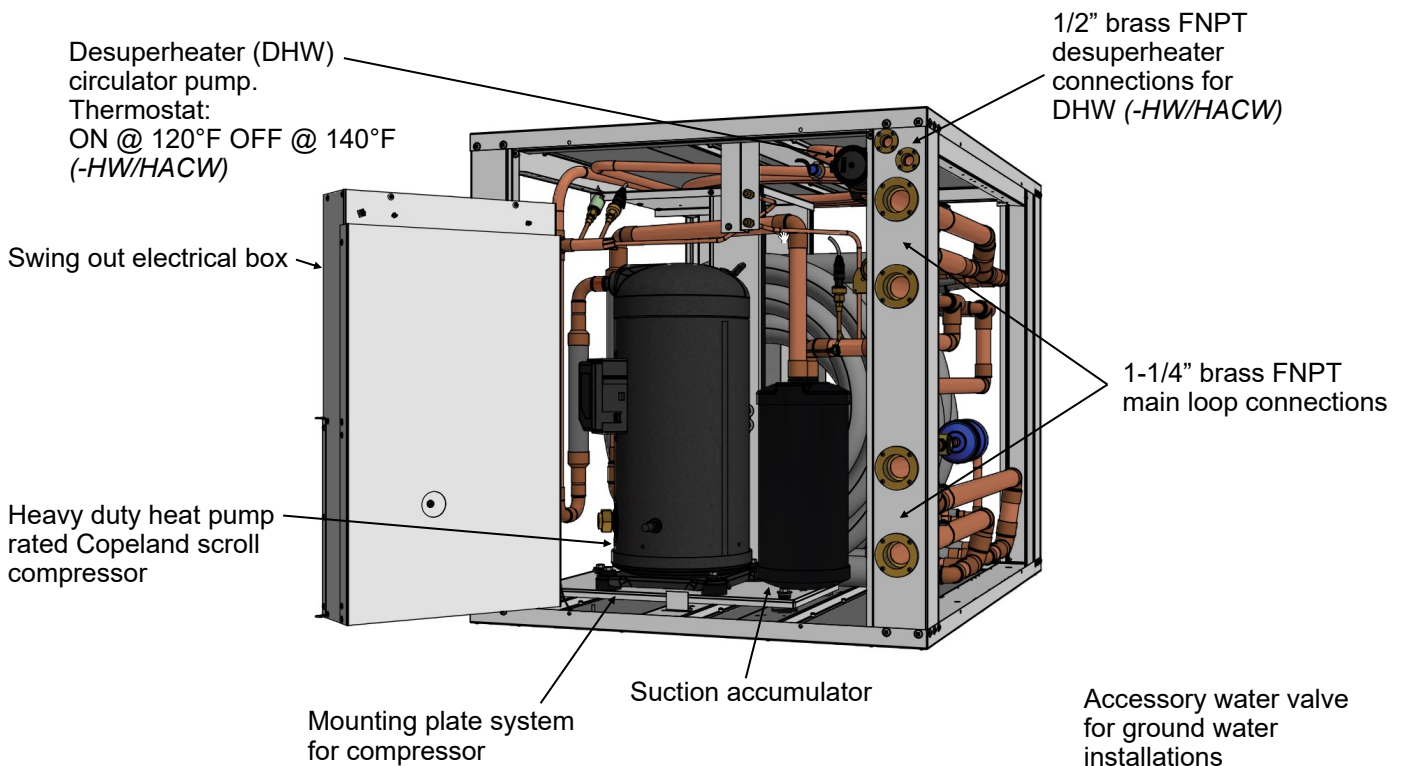
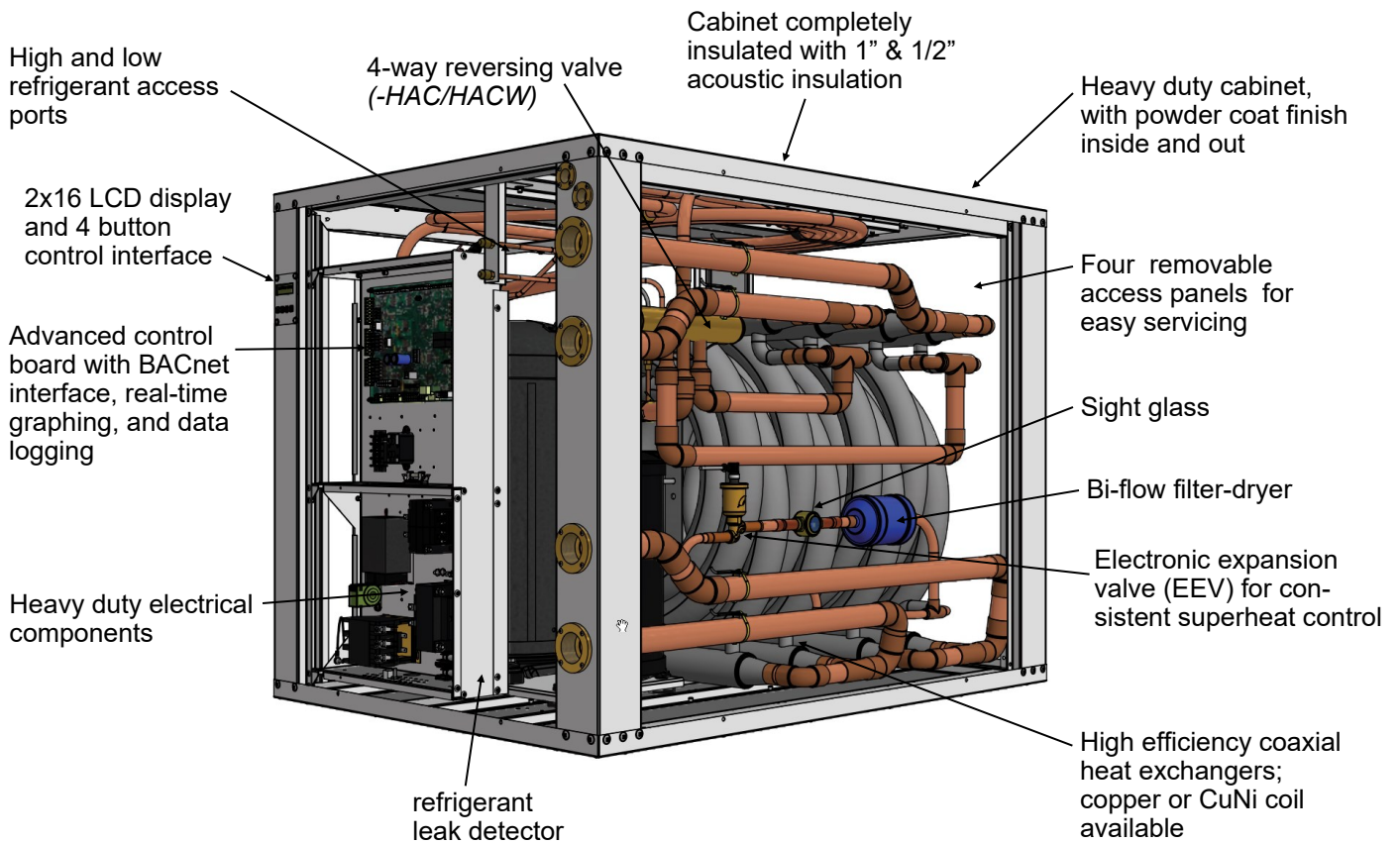

Dimensions: H/HAC Models

All dimensions in inches.

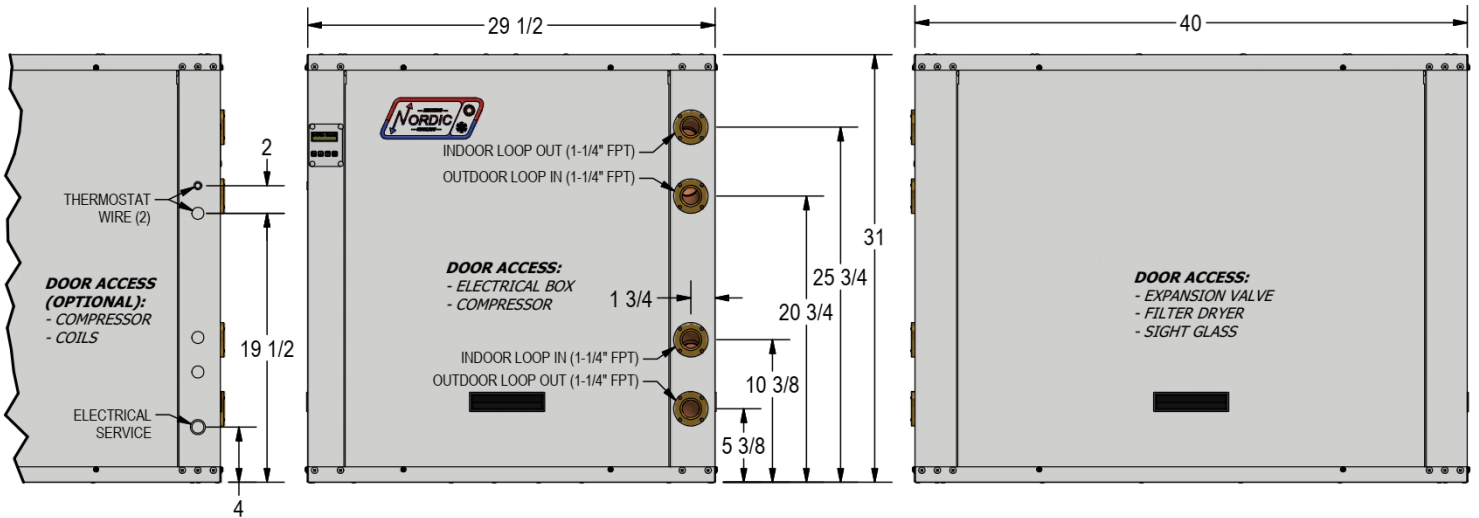

Dimensions: HW/HACW Models (with desuperheater)

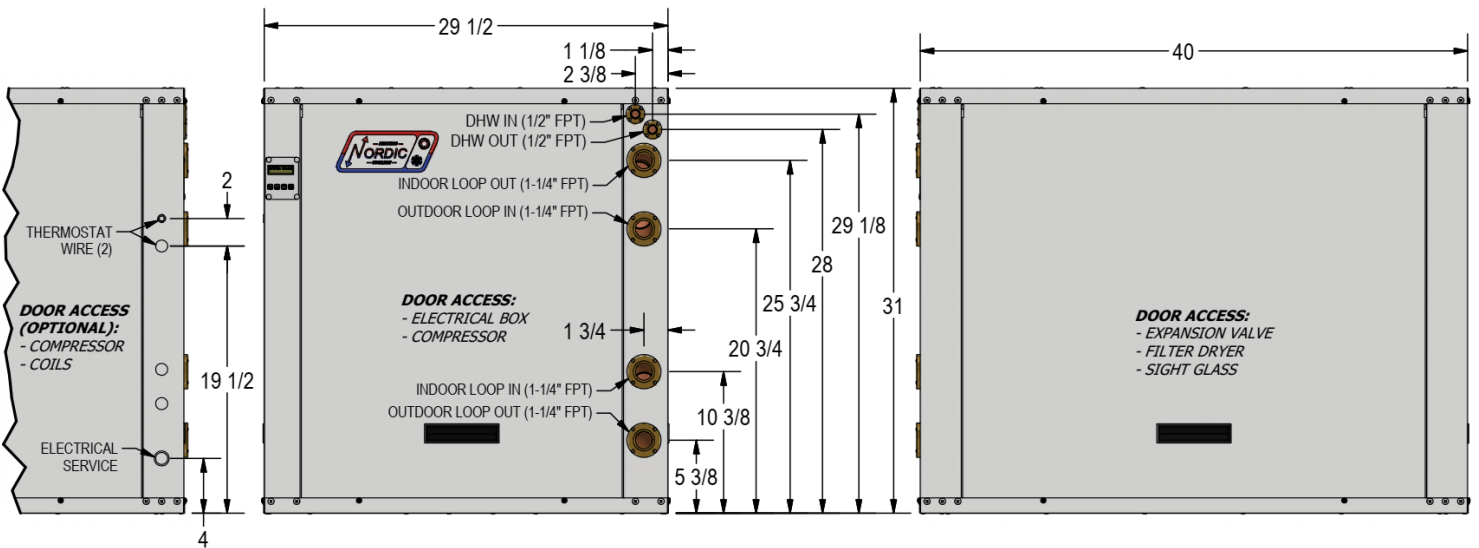

LEFT SIDE
CLEARANCE
OPTIONAL

RECOMMENDED
FRONT CLEARANCE:
3 FT

RECOMMENDED
RIGHT SIDE CLEARANCE:
3 FT

NO BACK SIDE CLEARANCE REQUIRED

Specifications

Electrical Specifications (R454b)

MODEL	Nomenclature Identifier	Power Supply			Compressors (each)		FLA	MCA	Maximum Fuse/Breaker	Minimum Wire Size
		V- ϕ -Hz	MIN	MAX	RLA	LRA	Amps	Amps	Amps	ga
W-100	2	208-3-60	187	229	28.5	255	29.4	36.5	60	#6-3
	4	460-3-60	414	506	13.5	123	14.4	17.8	30	#10-3
	5	575-3-60	518	632	10.7	94	11.6	14.3	20	#12-3

Refrigerant Charge

MODEL	TYPE	lb	kg	OIL
W-100	R454b	17	7.7	POE

- Oil capacity is marked on the compressor label.
 - Refrigerant charge is **subject to revision**; actual charge is indicated on the unit nameplate.

Shipping Information

MODEL	WEIGHT lb. (kg)	DIMENSIONS in (cm)		
		L	W	H
W-100	700 (318)	46 (117)	46 (117)	36 (92)

Standard Capacity Ratings - Ground Loop Heating* 60Hz

EWT 104°F (40°C) ELT 32°F (0°C)

MODEL	Liquid Flow (Outdoor & Indoor)		Input Energy	Capacity		COP _H
	gpm	L/s	Watts	Btu/hr	kW	W/W
W-100	28	1.8	7,347	78,500	23	3.13

* 35% Propylene Glycol by Volume Outdoor (Ground) Loop Fluid

Standard Capacity Ratings - Ground Water Heating 60Hz

EWT 104°F (40°C) ELT 50°F (10°C)

MODEL	Liquid Flow (Outdoor & Indoor)		Input Energy	Capacity		COP _H
	gpm	L/s	Watts	Btu/hr	kW	W/W
W-100	28	1.8	7,675	107,800	32	4.12

Standard Capacity Ratings - Ground Loop Cooling* 60Hz

EWT 53.6°F (12°C) ELT 77°F (25°C)

MODEL	Liquid Flow (Outdoor & Indoor)		Input Energy	Evap. Capacity		COP _c	EER
	gpm	L/s	Watts	Btu/hr	kW	W/W	Btu/hr/W
W-100	28	1.8	6,175	95,100	28	4.51	15.4

* 35% Propylene Glycol by Volume Outdoor (Ground) Loop Fluid

Standard Capacity Ratings - Ground Water Cooling 60Hz

EWT 53.6°F (12°C) ELT 59°F (15°C)

MODEL	Liquid Flow (Outdoor & Indoor)		Input Energy	Evap. Capacity		COP _c	EER
	gpm	L/s	Watts	Btu/hr	kW	W/W	Btu/hr/W
W-100	28	1.8	4,956	103,100	30	6.10	20.8

Specifications

Recommended Flow Rates				
MODEL	OUTDOOR LOOP		INDOOR LOOP (MAX. 130°F)	
	gpm(US)	L/s	gpm(US)	L/s
W-100	28	1.8	28	1.8

Heat Pump Holdup Volumes				
MODEL	OUTDOOR LOOP		INDOOR LOOP (SINGLE WALL '-PP')	
	US gal	L	US gal	L
W-100	3.05	11.5	3.30	12.5

W-SERIES Operating Temperature Limits					
Loop	Mode	Parameter	(°F)	(°C)	Note
Indoor Loop	HEATING (indoor is hot loop)	Minimum ELT/EWT	50	10	0-10VDC modulating water valve required on indoor loop at temperatures < 80°F (27°C), or manual flow reduction at startup
		Maximum LLT/LWT	130	54	
		Maximum LLT/LWT	140	60	Domestic hot water (DHW) heating with double wall condenser option and reduced flow rate.
	COOLING (reversing HAC units only, indoor is cold loop)	Minimum LWT	40	4	Indoor loop with water only (no antifreeze).
		Minimum LLT	-->	-->	Indoor loop with antifreeze: depends on antifreeze type & %
		Maximum ELT	80	27	0-10VDC modulating water valve required on indoor loop above this temperature, or manual flow reduction at startup
Outdoor Loop	HEATING (outdoor is cold loop)	Minimum LWT	37	3	For water loops without antifreeze, e.g. open loop systems
		Minimum LLT	-->	-->	Ground loop system: depends on antifreeze type and % settings.
		Maximum ELT/EWT	80	27	0-10VDC modulating water valve required on outdoor loop above this temperature to limit suction pressure
	COOLING (reversing HAC units only, outdoor is hot loop)	Minimum ELT/EWT	50	10	0-10VDC modulating water valve required on outdoor loop at temperatures < 80°F (27°C) to keep head pressure up
		Maximum LLT/LWT	130	54	

ELT: Entering Liquid Temperature (implies antifreeze present)
 LLT: Leaving Liquid Temperature (implies antifreeze present)
 EWT: Entering Water Temperature
 LWT: Leaving Water Temperature

Values in these tables are for rated liquid and water flows.

Specifications

**Pressure Drop Data
(US UNITS)**

		OUTDOOR LOOP & INDOOR LOOP				
		water 130°F	water 104°F	water 50°F	15% methanol 32°F	35% prop. glycol 32°F
W-100	USgpm	psi	psi	psi	psi	psi
	16	1.8	1.8	1.9	2.2	2.9
	20	2.4	2.4	2.6	3.3	4.3
	24	3.6	3.6	3.9	4.6	6.0
	28	4.7	4.7	5.0	5.8	7.6
	32	6.3	6.3	6.5	7.3	9.6

METRIC

**Pressure Drop Data
(METRIC UNITS)**

		OUTDOOR LOOP & INDOOR LOOP				
		water 130°F	water 104°F	water 50°F	15% methanol 32°F	35% prop. glycol 32°F
W-100	L/s	kPa	kPa	kPa	kPa	kPa
	1.0	12	12	13	15	20
	1.3	17	17	18	23	30
	1.5	25	25	27	32	41
	1.8	32	32	34	40	52
	2.0	43	43	45	50	66

Performance Tables - W-Series (US UNITS)

W-100-H***-X-*S-CC R454b, 60 Hz, YA104K1E-TFD (460-3-60)

*Compressor current is for 460-3-60.
Multiply by 2.2 for 208-3-60, by 0.8 for 575-3-60.

	EVAPORATOR LOOP (35% Propylene Glycol)						ELECTRICAL		CONDENSER LOOP (Water)									
	ELT (°F)	Evap. Temp.	Flow (gpm)	LLT (°F)	Delta T (°F)	Heat Abs. (Btu/hr)	Compressor Current (A)*	Input Power (W)	EWT (°F)	Cond. Temp.	Flow (gpm)	LWT (°F)	Delta T (°F)	Heating (Btu/hr)	COP _H			
HEATING	25	13	28	22	-3.5	45,600	10.4	7,187	104	115	28	109	4.9	69,000	2.81			
	30	18	28	26	-4.0	51,900	10.6	7,300					5.4	75,800	3.04			
	35	22	28	31	-4.5	58,500	10.7	7,410					5.9	82,800	3.27			
	40	27	28	35	-5.1	65,800	10.9	7,504					6.5	90,500	3.53			
	45	31	28	39	-5.7	73,700	11.0	7,598					7.1	98,800	3.81			
	50	36	28	44	-6.3	82,400	11.2	7,675					7.7	107,800	4.12			
	55	40	28	48	-7.0	91,800	11.3	7,746					8.4	117,500	4.45			
	60	45	28	52	-7.8	101,800	11.4	7,820					9.2	127,900	4.79			
	65	50	28	56	-8.6	112,900	11.6	7,879					10.0	139,200	5.18			
	70	54	28	61	-9.5	124,600	11.7	7,944					10.8	151,200	5.58			
	25	14	28	22	-3.2	41,400	11.2	7,923					115.2	125	28	4.8	67,300	2.49
	30	18	28	26	-3.6	47,300	11.3	7,997					114.7	125	28	5.3	73,600	2.70
	35	23	28	31	-4.1	53,800	11.4	8,062					114.2	125	28	5.8	80,300	2.92
	40	27	28	35	-4.7	60,900	11.6	8,123					113.7	125	28	6.3	87,700	3.16
45	32	28	40	-5.3	68,700	11.7	8,178	113.1	125	28	6.9	95,800	3.43					
50	36	28	44	-5.9	77,200	11.8	8,226	112.5	126	28	7.5	104,500	3.72					
55	41	28	48	-6.6	86,400	11.9	8,270	111.8	126	28	8.2	113,900	4.04					
60	45	28	53	-7.4	96,600	12.0	8,310	111.1	126	28	8.9	124,300	4.38					
65	50	28	57	-8.2	107,600	12.0	8,344	110.3	126	28	9.7	135,500	4.76					
70	54	28	61	-9.1	119,500	12.1	8,375	109.4	126	28	10.6	147,600	5.17					
DHW																		

N/A - coaxial coil condenser without double wall option

	EVAPORATOR LOOP (Water)						ELECTRICAL		CONDENSER LOOP (35% Propylene Glycol)						
	ELT (°F)	Evap. Temp.	Flow (gpm)	LLT (°F)	Delta T (°F)	Cooling (Btu/hr)	Compressor Current (A)*	Input Power (W)	EWT (°F)	Cond. Temp.	Flow (gpm)	LWT (°F)	Delta T (°F)	Heat Rej. (Btu/hr)	EER
COOLING	54	35	28	46	-7.7	107,200	7.5	4,349	50	73	28	59	9.3	121,000	24.6
		35	28	46	-7.5	105,100	7.8	4,691	55	78	28	64	9.2	120,100	22.4
		36	28	46	-7.4	103,000	8.1	5,020	60	83	28	69	9.1	119,100	20.5
		36	28	46	-7.2	100,700	8.5	5,356	65	88	28	74	9.0	118,000	18.8
		37	28	47	-7.1	98,400	8.8	5,693	70	94	28	79	8.9	116,800	17.3
		37	28	47	-6.9	96,100	9.2	6,032	75	99	28	84	8.8	115,700	15.9
		38	28	47	-6.7	93,600	9.6	6,389	80	104	28	89	8.7	114,400	14.7
		38	28	47	-6.5	91,100	10.0	6,765	85	109	28	94	8.6	113,200	13.5
		39	28	47	-6.4	88,600	10.4	7,153	90	114	28	99	8.5	112,000	12.4
		39	28	47	-6.2	85,800	10.9	7,574	95	119	28	103	8.4	110,700	11.3

Performance Tables - W-Series (METRIC UNITS)

W-100-H***-X-*S-CC R454b, 60 Hz, YA104K1E-TFD (460-3-60)

*Compressor current is for 460-3-60.
Multiply by 2.2 for 208-3-60, by 0.8 for 575-3-60.

METRIC

	EVAPORATOR LOOP (35% Propylene Glycol)						ELECTRICAL		CONDENSER LOOP (Water)							
	ELT (°C)	Evap. Temp.	Flow (L/s)	LLT (°C)	Delta T (°C)	Heat Abs. (kW)	Compressor Current (A)*	Input Power (W)	EWT (°C)	Cond. Temp.	Flow (L/s)	LWT (°C)	Delta T (°C)	Heating (kW)	COP _H	
HEATING	-3.9	-10.6	1.8	-5.8	-1.9	13.4	10.4	7,187	40		45.9	1.8	42.7	2.7	20.2	2.81
	-1.1	-8.0	1.8	-3.3	-2.2	15.2	10.6	7,300		46.3	1.8	43.0	3.0	22.2	3.04	
	1.7	-5.5	1.8	-0.8	-2.5	17.1	10.7	7,410		46.7	1.8	43.3	3.3	24.3	3.27	
	4.4	-2.9	1.8	1.6	-2.8	19.3	10.9	7,504		47.0	1.8	43.6	3.6	26.5	3.53	
	7.2	-0.4	1.8	4.0	-3.2	21.6	11.0	7,598		47.4	1.8	43.9	3.9	29.0	3.81	
	10.0	2.1	1.8	6.5	-3.5	24.1	11.2	7,675		47.7	1.8	44.3	4.3	31.6	4.12	
	12.8	4.7	1.8	8.9	-3.9	26.9	11.3	7,746		48.1	1.8	44.7	4.7	34.4	4.45	
	15.6	7.2	1.8	11.3	-4.3	29.8	11.4	7,820		48.4	1.8	45.1	5.1	37.5	4.79	
	18.3	9.7	1.8	13.5	-4.8	33.1	11.6	7,879		48.8	1.8	45.6	5.6	40.8	5.18	
	21.1	12.2	1.8	15.8	-5.3	36.5	11.7	7,944		49.2	1.8	46.0	6.0	44.3	5.58	
	-3.9	-10.1	1.8	-5.7	-1.8	12.1	11.2	7,923	46.2	51.4	1.8	49		2.7	19.7	2.49
	-1.1	-7.6	1.8	-3.1	-2.0	13.9	11.3	7,997	45.9	51.6	1.8		2.9	21.6	2.70	
	1.7	-5.1	1.8	-0.6	-2.3	15.8	11.4	8,062	45.7	51.7	1.8		3.2	23.5	2.92	
	4.4	-2.6	1.8	1.8	-2.6	17.8	11.6	8,123	45.4	51.8	1.8		3.5	25.7	3.16	
	7.2	-0.1	1.8	4.3	-2.9	20.1	11.7	8,178	45.1	51.9	1.8		3.8	28.1	3.43	
	10.0	2.4	1.8	6.7	-3.3	22.6	11.8	8,226	44.7	52.0	1.8		4.2	30.6	3.72	
	12.8	4.9	1.8	9.1	-3.7	25.3	11.9	8,270	44.3	52.1	1.8		4.6	33.4	4.04	
	15.6	7.4	1.8	11.5	-4.1	28.3	12.0	8,310	43.9	52.2	1.8		4.9	36.4	4.38	
	18.3	9.9	1.8	13.7	-4.6	31.5	12.0	8,344	43.5	52.3	1.8		5.4	39.7	4.76	
21.1	12.4	1.8	16.0	-5.1	35.0	12.1	8,375	43.0	52.4	1.8	5.9		43.3	5.17		
DHW																

N/A - coaxial coil condenser without double wall option

	EVAPORATOR LOOP (Water)						ELECTRICAL		CONDENSER LOOP (35% Propylene Glycol)						
	ELT (°C)	Evap. Temp.	Flow (L/s)	LLT (°C)	Delta T (°C)	Cooling (kW)	Compressor Current (A)*	Input Power (W)	EWT (°C)	Cond. Temp.	Flow (L/s)	LWT (°C)	Delta T (°C)	Heat Rej. (kW)	COP _C
COOLING	12	1.5	1.8	7.7	-4.3	31.4	7.5	4,349	10.0	22.7	1.8	15.2	5.2	35.5	7.21
		1.8	1.8	7.8	-4.2	30.8	7.8	4,691	12.8	25.6	1.8	17.9	5.1	35.2	6.56
		2.1	1.8	7.9	-4.1	30.2	8.1	5,020	15.6	28.4	1.8	20.7	5.1	34.9	6.01
		2.3	1.8	8.0	-4.0	29.5	8.5	5,356	18.3	31.3	1.8	23.3	5.0	34.6	5.51
		2.6	1.8	8.1	-3.9	28.8	8.8	5,693	21.1	34.2	1.8	26.0	4.9	34.2	5.07
		2.9	1.8	8.2	-3.8	28.2	9.2	6,032	23.9	37.0	1.8	28.8	4.9	33.9	4.66
		3.2	1.8	8.3	-3.7	27.4	9.6	6,389	26.7	39.9	1.8	31.5	4.8	33.5	4.31
		3.4	1.8	8.4	-3.6	26.7	10.0	6,765	29.4	42.8	1.8	34.2	4.8	33.2	3.96
		3.7	1.8	8.4	-3.6	26.0	10.4	7,153	32.2	45.6	1.8	36.9	4.7	32.8	3.63
4.0	1.8	8.6	-3.4	25.1	10.9	7,574	35.0	48.5	1.8	39.7	4.7	32.4	3.31		

W/WH-Commercial Schematic Diagram - Single Circuit / Single Compressor (-H/HAC)

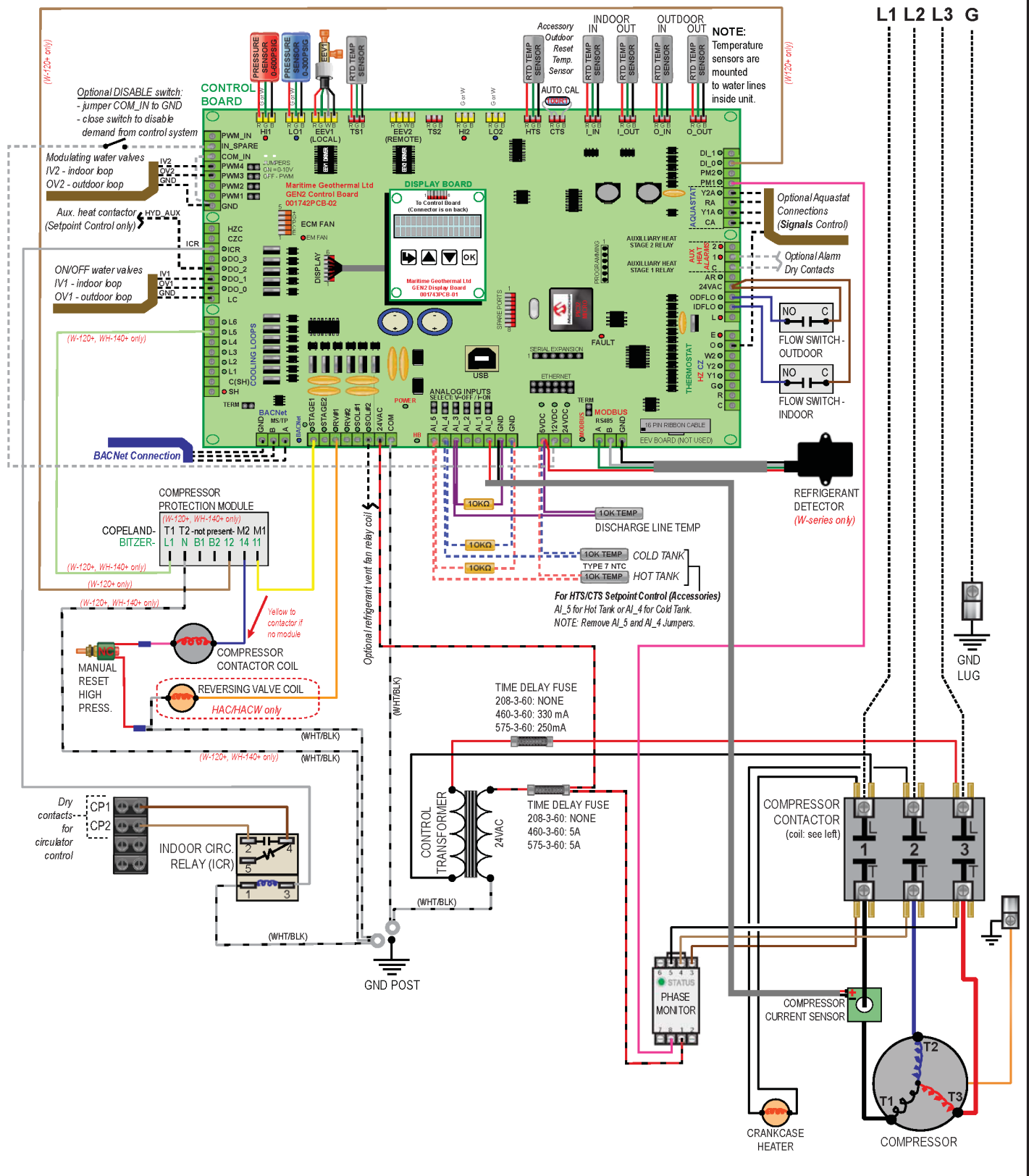

Drawn By D. RHEAULT	Date 23-SEP-2024		P.O. Box 2555 170 Plantation Rd. Petitcodiac, NB CANADA E4Z 6H4	
Checked By D. RHEAULT	Date 23-SEP-2024		Drawing Name W/WH-Single Compressor Schematic Diagram (-H/HAC)	
Eng. Approved By	Date		Size LET	Drawing Number 002753SCH
Mfg. Approved By	Date		Drawing Rev 01	Sheet 1 / 1
Approved By	Date			

W/WH-90/100 Electrical Box Diagram

Scroll / Reversing / BACNet Interface Optional Domestic Hot Water

DANGER: HIGH VOLTAGE. Ensure power is off before opening the electrical box cover.

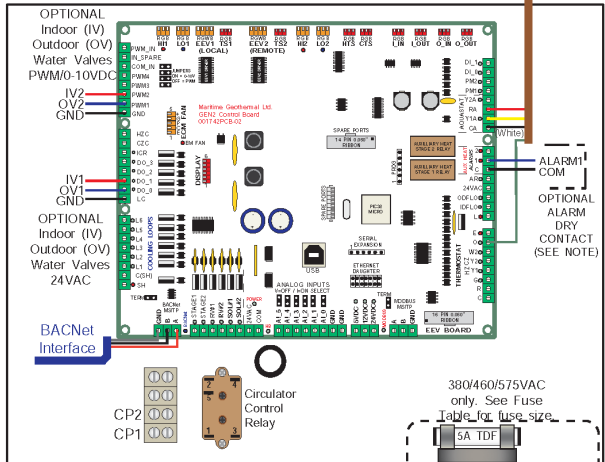

DHW wire with insulated terminal connects here:

208 VAC models: Brown wire

380/460/575 VAC models: Black wire

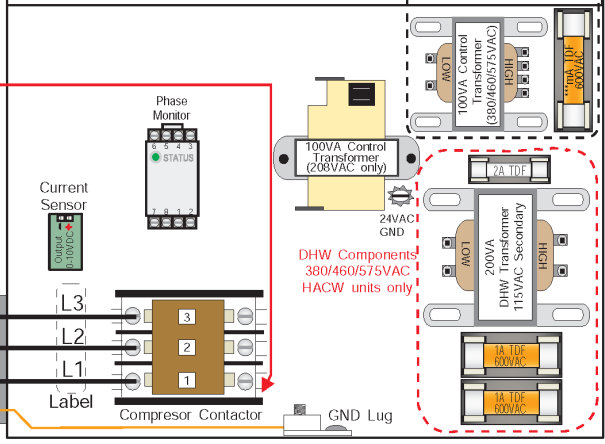

DHW NOTE: If the heat pump is to be operated without the hot water circulator connected to the water tank and flooded with water, remove the brown (or light brown) wire with the insulated terminal from the location(s) shown in the diagram above. **The pump is water lubricated and must not be run dry.**

CONTROL CONNECTIONS (HARD WIRED / SIGNALS OPTION)

RA(24VAC)

Y1A(Compressor #1)

CA(Common)

O(Cooling)

POWER SUPPLY CONNECTIONS	
Wire	Compressor Contactor
Line 3	L3
Line 2	L2
Line 1	L1

Connect "Gnd" to Gnd. Lug

FUSE TABLE ***	
Supply Voltage	Fuse Value*
208-3-60	-----
460-3-60	330mA
575-3-60	250mA
380-3-50	500mA

*Value is marked in electrical box.

IMPORTANT NOTE FOR 3 PHASE SCROLL COMPRESSORS
This unit is equipped with a scroll compressor which must rotate in the proper direction. After the initial connection, if the phase protection module(s) indicate a fault on power up, turn the power off and reverse the L1 and L2 supply leads. Turn the power on and clear the fault(s).

DANGER: HIGH VOLTAGE. Ensure power is off before opening the electrical box cover.

NOTE: Control of the unit is done either via the BACNet interface, Setpoint Control or low voltage wiring.

BACNet Interface (MS/TP) (RS-485)

Use twisted pair shielded conductor cable.

- A - Communication
- B - Communication
- GND - Ground

NOTE: There is a 5 minute anti-short cycle timer for the compressor.

NOTE: CP1 and CP2 provide a dry contact that can be used as a control signal to turn on circulator pumps when the compressor starts.
MAX 5amps @ 24VAC

Low Voltage Wiring (24VAC)

Use an 18-5 conductor cable.

- C - 24VAC Common
- R - 24VAC Hot
- Y1A - Stage 1 (Compressor#1)
- O - Heating/Cooling Mode (active for cooling mode)

A dry contact from R to Y1 will start compressor.

A dry contact from R to O will activate cooling mode.

NOTE: 24VAC is present across OV1 and GND in heating mode (IV1 and GND in cooling mode) to power an external water valve when either compressor starts.
MAX 1amp @ 24VAC

NOTE: Alarm1 signals are dry contacts (NO), max 1A@24VAC each. Connect the signal source to COM. Alarm1 relay will be energized when a permanent alarm occurs.

01	ISSUE 02	D. RHEAULT	D. RHEAULT	1 APR 2022	Drawn by Chris Geddes	Date 14 NOV 2014	MARITIME GEOTHERMAL LTD. 170 Plantation Rd. Pentecostiac, NB E4Z 6H4
01	000226 (IR)	C. GEDDES	C. GEDDES	14 NOV 2014	Checked by Chris Geddes	Date 14 NOV 2014	
REV	ECO #	IMPL BY	APVD BY	DATE	Approved By Chris Geddes	Date 14 NOV 2014	Drawing Name W/WH-90/100-H***-S-***
					Approved By	Date	Size A
							Drawing Number 001904ELB
							Drawing Rev 01(i2)
							Sheet 1 of 1

Refrigeration Circuit Diagram: H/HW Models

W-90/100 Refrigeration Circuit Heating Only

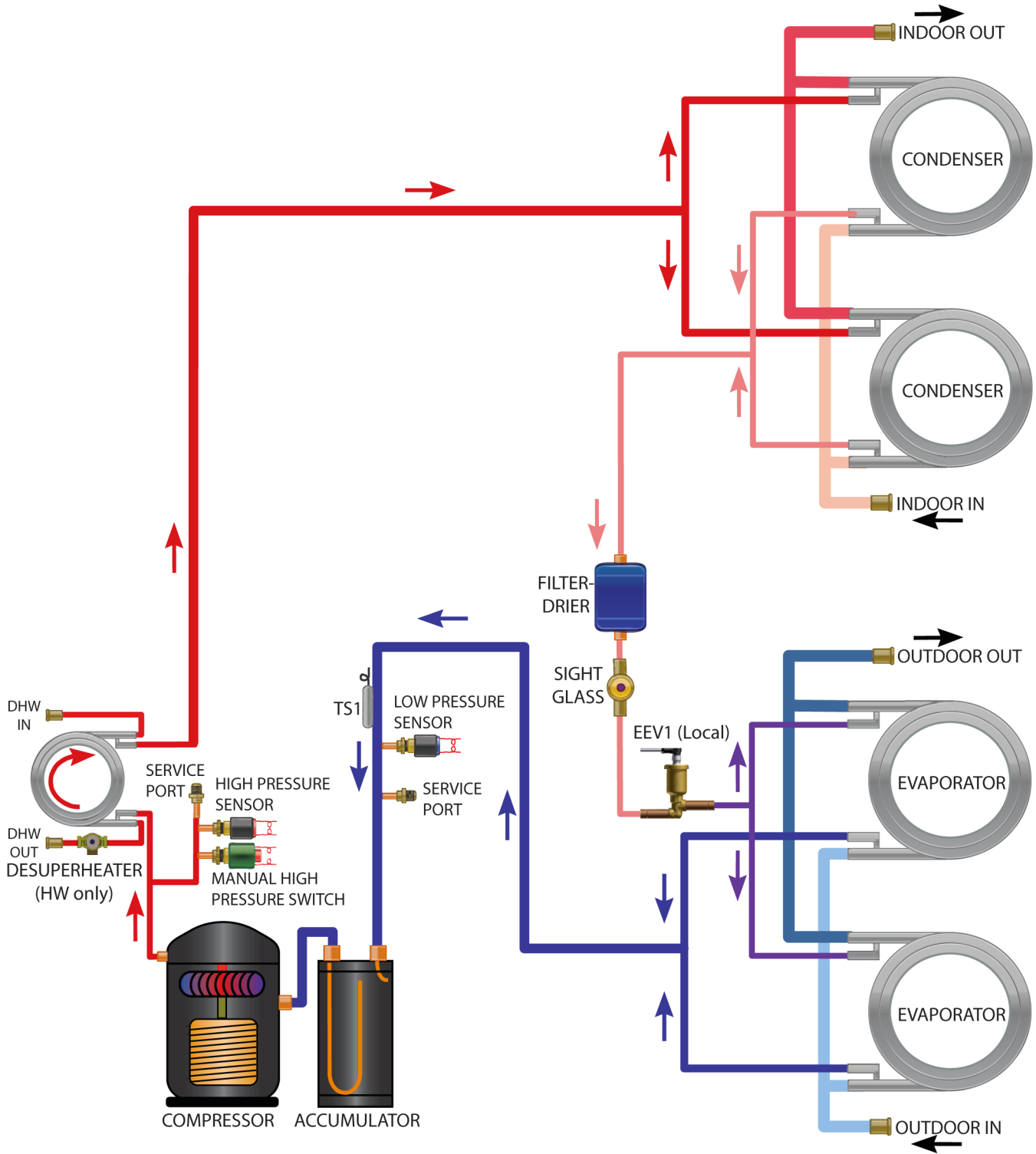

					Drawn By C.GEDDES Date 04 MAY 2014	MARITIME GEOTHERMAL LTD. P.O. Box 2555 170 Plantation Rd. Petitcodiac, NB CANADA E4Z 6H4
					Checked By C.GEDDES Date 04 MAY 2014	
					Eng. Approved By C.GEDDES Date 04 MAY 2014	Drawing Name W-90/100 EEV Refrigeration Circuit Heating Only
					Mfg. Approved By Date	
					Approved By Date	Size LET
02	000226	C. GEDDES	C. GEDDES	15 NOV 2014		Drawing Number 000995RCD
01	Initial Release	C. GEDDES	C. GEDDES	04 MAY 2009		Drawing Revision 02
REV	ECO#	IMPL BY	APVD BY	DATE		Sheet 1 / 1

Refrigeration Circuit Diagram: HAC/HACW Models

ITEM	STATUS
RV#1	DE-ENERGIZED

W-90/100 Refrigeration Circuit Heating Mode

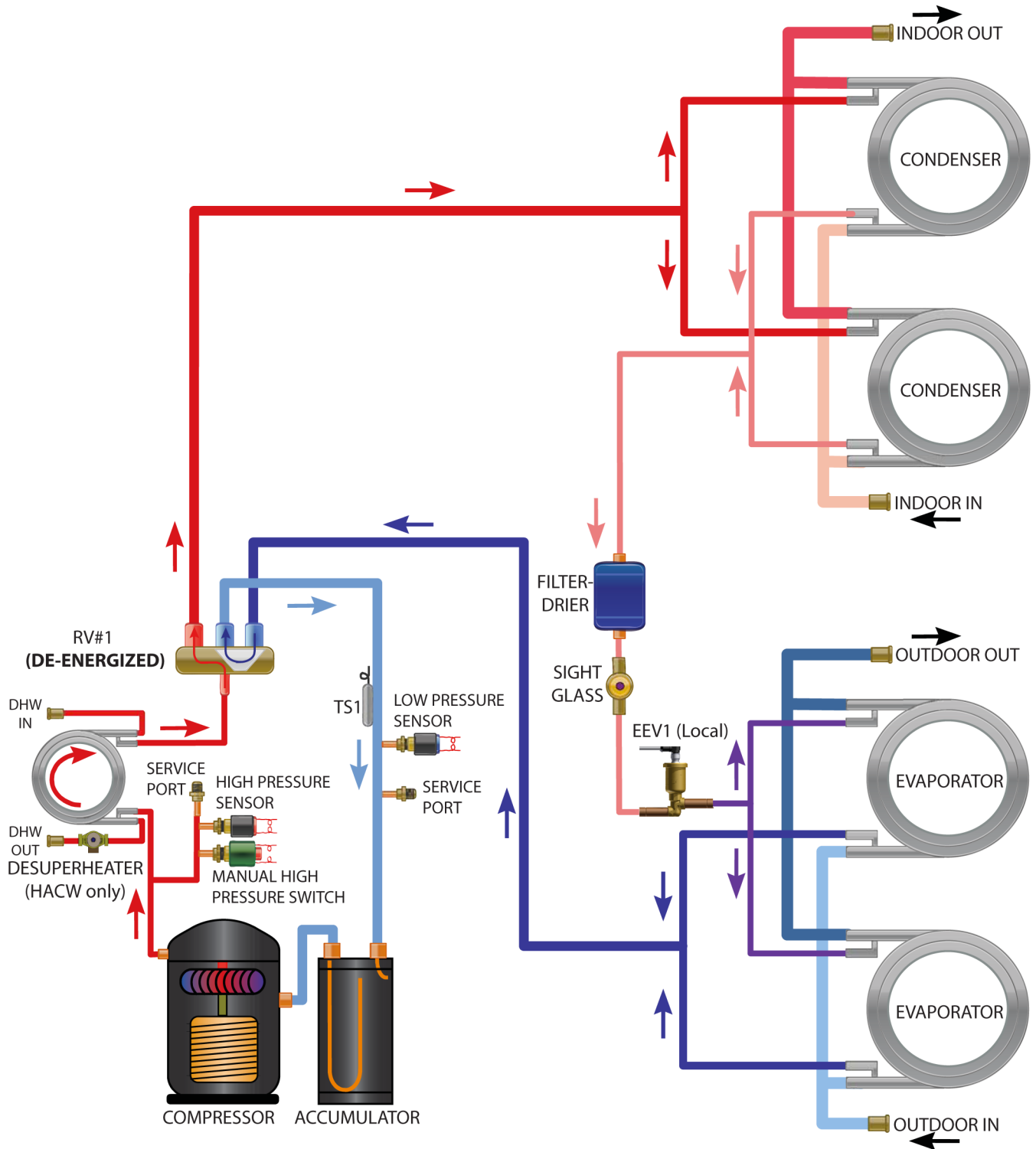

02	000226	C. GEDDES	C. GEDDES	15 NOV 2014	Drawn By C.GEDDES	Date 04 MAY 2014	MARITIME GEOTHERMAL LTD. P.O. Box 2555 170 Plantation Rd. Petitcodiac, NB CANADA E4Z 6H4
01	Initial Release	C. GEDDES	C. GEDDES	04 MAY 2009	Checked By C.GEDDES	Date 04 MAY 2014	
REV	ECO#	IMPL BY	APVD BY	DATE	Eng. Approved By C.GEDDES	Date 04 MAY 2014	Drawing Name W-90/100 EEV Refrigeration Circuit Heating Mode
					Mfg. Approved By	Date	Size LET
					Approved By	Date	Drawing Number 000992RCD
							Drawing Revision 02
							Sheet 1 / 1

Refrigeration Circuit Diagram: HAC/HACW Models

ITEM	STATUS
RV#1	ENERGIZED

W-90/100 Refrigeration Circuit Cooling Mode

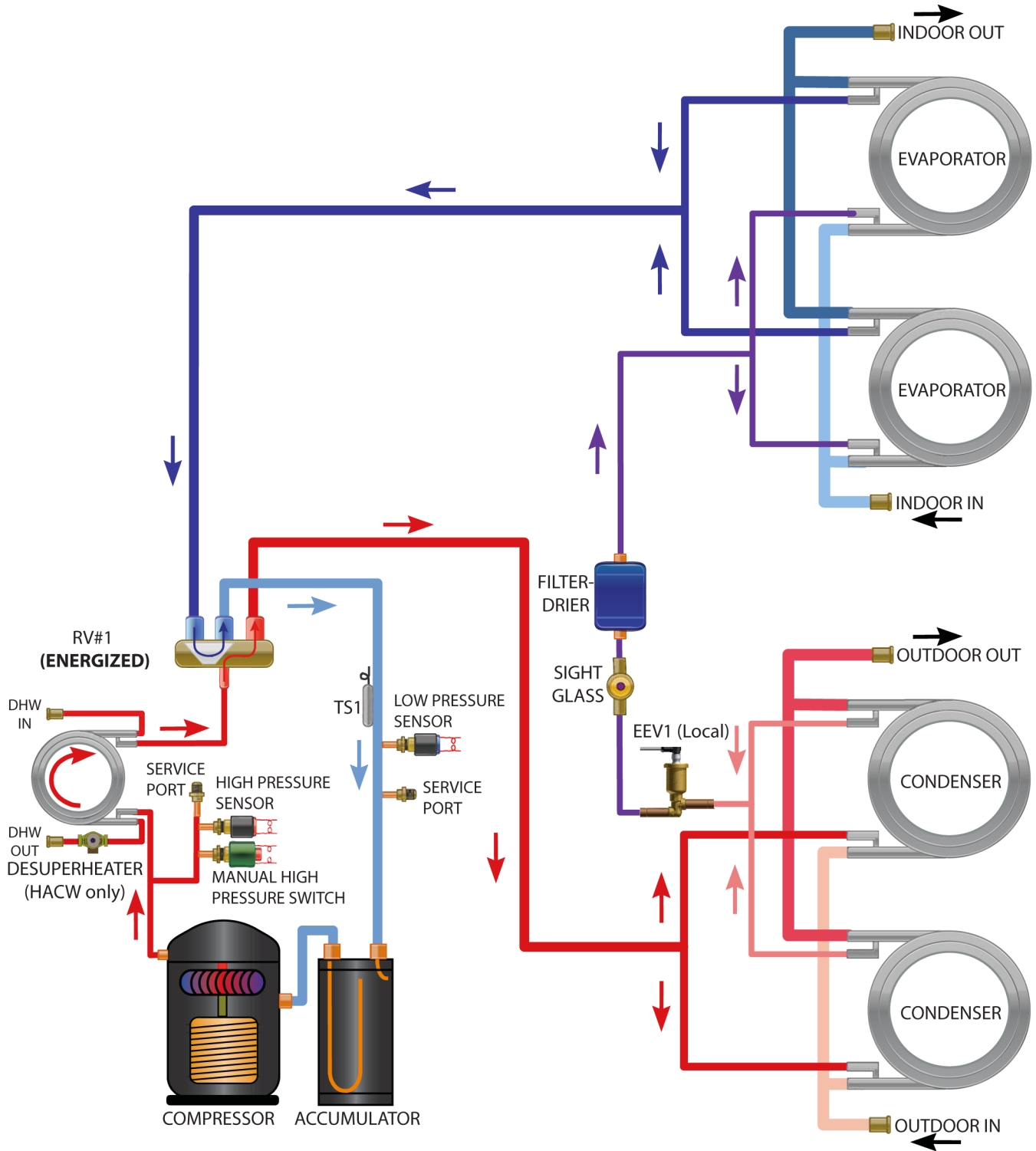

02	000226	C. GEDDES	C. GEDDES	15 NOV 2014	Drawn By C.GEDDES	Date 04 MAY 2014	MARITIME GEOTHERMAL LTD. P.O. Box 2555 170 Plantation Rd. Petitcodiac, NB CANADA E4Z 6H4
01	Initial Release	C. GEDDES	C. GEDDES	04 MAY 2009	Checked By C.GEDDES	Date 04 MAY 2014	
REV	ECO#	IMPL BY	APVD BY	DATE	Eng. Approved By C.GEDDES	Date 04 MAY 2014	Drawing Name W-90/100 EEV Refrigeration Circuit Cooling Mode
					Mfg. Approved By	Date	Size LET
					Approved By	Date	Drawing Number 000993RCD
							Drawing Revision 02
							Sheet 1 / 1

BACnet Interface

The BACnet interface is an **MS/TP** connection via RS-485 twisted pair. BACnet **IP** is not available.
Recommended wire: 22-24 AWG single twisted pair, 100-120 Ohms impedance, 17pF/ft or lower capacitance, with braided or aluminum foil shield, such as Belden 9841 or 89841.

The connector on the control board is a three wire removable screw connector. The signals are as follows:

- A: Communications line (+) (right pin)
- B: Communications line (-) (middle pin)
- C: Ground connection (left pin)

If connecting multiple units to one RS-485 connection point, connect the signal cable from the master building controller to the first unit. Connect the second unit to the first unit (in same connector), connect the third unit to the second unit, and so on until all units are connected (daisy-chain). Remove the TERM jumper (located just above the BACnet connector on control board) from all units except the last one. The shield ground should be connected only to the GND pin of the unit for single unit installations. For multiple units, the shield ground should only be connected to the GND pin of the last unit. The shield grounds for intermediate units should be connected together. The shield ground should be left unconnected at the building controller end for all cases.

Vendor: Maritime Geothermal Ltd.
Vendor ID: 260
Model Name: MGT GEN2 Control Board

The following parameters can be set
PC App's Configuration Window:

- 1) **Baud rate**
9600, 19200, 38400, or 76800
- 2) **MAC address**
Maximum value is 125.
- 3) **Instance number**
Maximum value is 4194303.

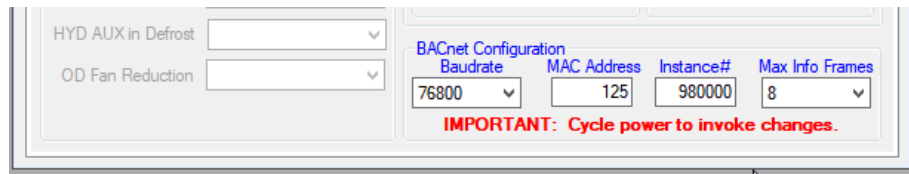

via the

The BACnet parameter **Max_Master** has a fixed value of **127** in this device.

BACnet data is available regardless of the selected control method. In order to control the unit via the BACnet interface, set **Control Source** to **BACnet** either by using the PC App's configuration window or the LCD menus.

For tables listing BACnet objects, refer to **Application, Installation, and Service Manual**.

Engineering Guide Specifications

General

The water-to-water heat pump shall be a single packaged single refrigeration circuit heating / cooling unit, with optional desuperheating circuit for domestic hot water heating. The unit shall be listed by a nationally recognized safety-testing laboratory (NRTL), such as TUV, ETL, UL, or CSA. The unit shall be rated in accordance with applicable standards of the Air Conditioning, Heating, and Refrigeration Institute / International Standards Organization (AHRI/ISO) and/or Canadian Standards Association (CSA). The liquid source water to water heat pump unit, as manufactured by Maritime Geothermal, Petitcodiac, New Brunswick, shall be designed to operate correctly within liquid temperature ranges specified on the "Minimum and Maximum Operating Temperatures" page of this engineering specification document.

Factory Quality

Each unit shall be run tested at the factory with water circulating through the indoor and outdoor loops. Quality control system checks shall include: computerized nitrogen pressurized leak test, evacuation of refrigeration circuit to sustained vacuum, accurate system charge, detailed heating and cooling mode tests, and quality cross check all operational and test conditions to pass/fail criteria. Units tested without water flow are not acceptable. The units shall be warranted by the manufacturer against defects in materials and workmanship in accordance with the warranty section at the end of this document. Optional extended factory warranty coverage may be available.

Cabinet

Each unit shall be enclosed in a sheet metal cabinet. Cabinet shall be constructed of powder coated galvanized sheet metal of minimum 20 gauge. Sheet metal gauge shall be higher where structurally required. Design and construction of cabinet shall be such that it is rigid and passes the CSA/UL Loading Test requirements (200 lb roof test and 25 lb guard test). All panels shall be lined with minimum 1/2 inch [12.7 mm] thick acoustic type glass fiber insulation. All insulation shall meet the fire retardant provisions of NFPA 90A. This material shall also provide acoustical benefit. The unit must have a minimum of three access panels for serviceability of the compressor compartment. Units having only one access panel to compressor/heat exchangers/expansion device/refrigerant piping shall not be acceptable. The electrical box shall have separate holes and knockouts for entrance of line voltage and low voltage control wiring. All factory-installed wiring passing through factory knockouts and openings shall be protected from sheet metal edges at openings by plastic grommets.

Refrigerant Circuit

All units shall contain only one sealed refrigerant circuit, containing a hermetic motor scroll compressor, Electronic Expansion Valve (EEV), coaxial heat exchangers, factory installed high and low pressure sensors, manual reset high pressure switch, service ports, liquid line filter-drier, sight glass, and suction accumulator.

Refrigerant used shall have a global warming potential (GWP) of less than 500. A refrigerant leak detector shall be factory installed.

Compressors shall be specified for heat pump duty with internal isolation consisting of rubber vibration isolators and mounting plate with rubber vibration isolators. Compressor motors shall have internal high temperature overload protection.

The water to refrigerant heat exchangers shall consist of a steel outer jacket with twisted copper inner tube, designed and certified for 600 psig [4136 kPa] working pressure on the refrigerant side and 450 psig [3108 kPa] on the water side. Heat exchangers headered together in parallel shall use a reverse-return or symmetrical arrangement on the water side and symmetrical arrangement on the refrigerant side to ensure even flow splitting. Heat exchangers shall be insulated over all of their outside surface with minimum 3/8" thick closed cell insulation. Insulation consisting of 1/8" closed-cell insulating tape shall not be acceptable. Cupro-nickel (CuNi) inner tube shall be available as a factory option.

The electronic expansion valve shall be of stepper-motor rather than pulsing type, and shall provide proper superheat control over the unit's operating range with minimal deviation from superheat setpoint. Superheat shall be determined through the suction pressure-temperature method. Externally mounted pressure controlled water regulating flow valves or thermostatic expansion valves (TXV's) in place of electronic expansion valves are not acceptable.

The suction accumulator shall be insulated with minimum 3/8" thick closed cell insulation to prevent condensation. The accumulator's internal oil return port shall be sized properly for the unit's operating range. To ensure proper oil return, suction accumulator shall not be 'oversized'.

Piping and Connections

The unit shall have two sets of primary water in and out connections (for indoor and outdoor loops). The primary connection type shall be 1-1/4" nominal female National Pipe Thread (NPT). Domestic hot water (desuperheater) water connectors shall be 1/2" nominal female National Pipe Thread (NPT). All water connectors shall be rigidly mounted to cabinet with corrosion resistant fasteners to prevent relative movement. All water connectors shall be constructed of copper or brass material for corrosion resistance.

All internal water and refrigerant piping shall be insulated with minimum 3/8" thick closed cell insulation. Insulation consisting of 1/8" closed-cell insulating tape shall not be acceptable.

Electrical

Controls and safety devices shall be factory wired and mounted within the unit. Controls shall include 24 volt alternating current (24VAC) activated compressor contactors, reversing valves, and 24VAC 100VA transformer with built in circuit breaker or fused on both primary and secondary sides. Units shall be name-plated for use with time delay fuses or circuit breakers. Unit controls shall be 24VAC and provide heating or cooling as required by the remote thermostat or on-board controller. 3-phase protection shall be present in each unit to protect the compressor against loss of phase and reverse rotation. 3-phase protection shall be factory installed. Unit shall have dry contacts for controlling loop circulating pumps via an external 24VAC contactor. Unit shall provide remote fault indication to the control system via serial communication and fault messages on front panel LCD display.

Unit Control

The control system shall have the following features:

1. Anti-short cycle time delay on compressor operation. Time delay shall be a minimum of 5 minutes, for both thermostat demand and safety control reset starts. An override shall be provided to disable this delay for unit commissioning and testing purposes.
2. Random compressor start delay of 0-120 seconds on unit power up to facilitate starting multiple units after a power failure.
3. Flow switch on outdoor loop, and also on indoor loop for reversing units.
4. Compressor shutdown for high or low refrigerant pressures, low flow conditions and for phase protection faults.
5. Automatic intelligent reset: unit shall automatically restart 5 minutes after trip if the fault has cleared. Should a fault reoccur 3 times sequentially then permanent lockout shall occur, requiring cycling of the power to the unit in order to reset.
6. Manual reset high pressure in case of electronic board failure.
7. The low pressure shall not be monitored for the first 90 seconds after a compressor start to prevent nuisance safety trips.
8. 2 x 16 backlit Liquid Crystal Display (LCD) and four buttons for limited data access. Unit may be configured for stand alone operation with optional temperature sensor(s)
9. Universal Serial Bus (USB) port for full data access and diagnostic information, including real-time charting and data-logging
10. BACnet connectivity for control by building automation system, and providing alarm feedback.

Maritime Geothermal works continually to improve its products. As a result, the design and specifications of any product may be changed without notice. Please contact Maritime Geothermal at 1-506-756-8135 or visit www.nordicghp.com for latest design and specifications. Purchaser's approval of this data set signifies that the equipment is acceptable under the provisions of the job specification. Statements and other information contained herein are not express warranties and do not form the basis of any commercial contract or other agreement between any parties, but are merely Maritime Geothermal's statement of opinion regarding its products.

Warranty: W/WH-Commercial Series

COMMERCIAL LIMITED EXPRESS WARRANTY

Unless a statement is specifically identified as a warranty, statements made by Maritime Geothermal Ltd. ("MG") or its representatives relating to MG's products, whether oral, written or contained in any sales literature, catalogue or agreement, are not express warranties and do not form a part of the basis of the bargain, but are merely MG's opinion or commendation of MG's products.

SET FORTH HERE IS THE ONLY EXPRESS WARRANTY THAT APPLIES TO MG'S PRODUCTS. MG MAKES NO WARRANTY AGAINST LATENT DEFECTS. MG MAKES NO WARRANTY OF MERCHANTABILITY OF THE GOODS OR OF THE FITNESS OF THE GOODS FOR ANY PARTICULAR PURPOSE.

LIMITED EXPRESS COMMERCIAL WARRANTY - PARTS

MG warrants its Commercial Class products, purchased and retained in the United States of America and Canada, to be free from defects in material and workmanship under normal use and maintenance as follows:

- (1) Heat pumps / chillers built or sold by MG for one (1) year from the Warranty Inception Date (as defined below).
- (2) Compressors of above units for five (5) years from the Warranty Inception Date (as defined below).
- (3) Other accessories, when purchased separately, for (1) year from the date of shipment from MG.

The "Warranty Inception Date" shall be the date of original unit installation, as per the date on the installation Startup Record; or sixty (60) days from date of unit shipment from MG, whichever comes first.

To make a claim under this warranty, parts must be returned to MG in Petitcodiac, New Brunswick, freight prepaid, no later than ninety (90) days after the date of the failure of the part. If MG determines the part to be defective and within MG's Limited Express Commercial Warranty, MG shall, when such part has been either replaced or repaired, return such to a factory recognized distributor, dealer or service organization, freight prepaid. The warranty on any part repaired or replaced under warranty expires at the end of the original warranty period.

LIMITED EXPRESS COMMERCIAL WARRANTY - LABOUR

MARITIME GEOTHERMAL LTD. will not be responsible for any consequential damages or labour costs incurred.

This warranty does not cover and does not apply to:

- (1) Air filters, fuses, refrigerant, fluids, oil.
- (2) Products relocated after initial installation.
- (3) Any portion or component of any system that is not supplied by MG, regardless of the cause of the failure of such portion or component.
- (4) Products on which the unit identification tags or labels have been removed or defaced.
- (5) Products on which payment to MG, or to the owner's seller or installing contractor, is in default.
- (6) Products subjected to improper or inadequate installation, including but not limited to:
 - Indoor or outdoor loop flow lower than listed in engineering specification or as expressly approved by MARITIME GEOTHERMAL LTD.
 - Operating the heat pump either manually or with automated controls so that the unit is forced to function outside its normal operating range
 - Disabling of safety controls
 - Insufficient loop antifreeze concentration for loop temperature, or antifreeze concentration incorrectly set in control board
 - Fouled heat exchangers due to poor water quality
 - Failure to use strainers or clean them regularly
 - Impact or physical damage sustained by the heat pump
 - Poor refrigeration maintenance practices, including brazing without nitrogen flow, or using wrong braze/flux
 - Incorrect voltage or missing phase supplied to unit
 - Unit modified electrically or mechanically from factory supplied condition
 - Water quality outside of recommended limits (e.g. salinity or pH)
 - Unit not mounted with supplied anti-vibration grommets when specified for use
 - Corrosion damage due to corrosive ambient environment
 - Failure due to excessive cycling caused by improper mechanical setup or improperly programmed external controller
 - Physical loads or pressures placed on unit from external equipment
- (7) Mold, fungus or bacteria damage
- (8) Corrosion or abrasion of the product.
- (9) Products supplied by others.
- (10) Electricity or fuel, or any increases or unrealized savings in same, for any reason whatsoever.

MG is not responsible for:

- (1) The costs of fluids, refrigerant or system components **supplied by others**, or associated **labour** to repair or replace the same, which is incurred as a result of a defective part covered by MG's Limited Commercial Warranty.
- (2) The costs of **labour**, refrigerant, materials, or service incurred in diagnosis and removal of defective part, or in obtaining and replacing the new or repaired part.
- (3) Transportation costs of the defective part from the installation site to MG, or of the return of that part if warranty coverage declined.
- (4) The costs of normal maintenance.

MG'S LIABILITY UNDER THE TERMS OF THIS LIMITED WARRANTY SHALL APPLY ONLY TO THE MG UNITS REGISTERED WITH MG THAT BEAR THE MODEL AND SERIAL NUMBERS STATED ON THE INSTALLATION START UP RECORD, AND MG SHALL NOT, IN ANY EVENT, BE LIABLE UNDER THE TERMS OF THIS LIMITED WARRANTY UNLESS THIS INSTALLATION START UP RECORD HAS BEEN ENDORSED BY OWNER & DEALER/INSTALLER AND RECEIVED BY MG LIMITED WITHIN 90 DAYS OF START UP.

Limitation: This Limited Express Commercial Warranty is given in lieu of all other warranties. If, notwithstanding the disclaimers contained herein, it is determined that other warranties exist, any such express warranty, including without limitation any express warranties or any implied warranties of fitness for particular purpose and merchantability, shall be limited to the duration of the Limited Express Commercial Warranty.

LIMITATION OF REMEDIES

In the event of a breach of the Limited Express Commercial Warranty, MG will only be obligated at MG's option to repair the failed part or unit, or to furnish a new or rebuilt part or unit in exchange for the part or unit which has failed. If after written notice to MG's factory in Petitcodiac, New Brunswick of each defect, malfunction or other failure, and a reasonable number of attempts by MG to correct the defect, malfunction or other failure, and the remedy fails of its essential purpose, MG shall refund the purchase price paid to MG in exchange for the return of the sold good(s). Said refund shall be the maximum liability of MG. **THIS REMEDY IS THE SOLE AND EXCLUSIVE REMEDY OF THE BUYER OR PURCHASER AGAINST MG FOR BREACH OF CONTRACT, FOR THE BREACH OF ANY WARRANTY OR FOR MG'S NEGLIGENCE OR IN STRICT LIABILITY.**

LIMITATION OF LIABILITY

MG shall have no liability for any damages if MG's performance is delayed for any reason or is prevented to any extent by any event such as, but not limited to: any war, civil unrest, government restrictions or restraints, strikes, or work stoppages, fire, flood, accident, shortages of transportation, fuel, material, or labour, acts of God or any other reason beyond the sole control of MG. **MG EXPRESSLY DISCLAIMS AND EXCLUDES ANY LIABILITY FOR CONSEQUENTIAL OR INCIDENTAL DAMAGE IN CONTRACT, FOR BREACH OF ANY EXPRESS OR IMPLIED WARRANTY, OR IN TORT, WHETHER FOR MG'S NEGLIGENCE OR AS STRICT LIABILITY.**

OBTAINING WARRANTY PERFORMANCE

Normally, the dealer or service organization who installed the products will provide warranty performance for the owner. Should the installer be unavailable, contact any MG recognized distributor, dealer or service organization. If assistance is required in obtaining warranty performance, write or call Maritime Geothermal Ltd.

NOTE: Some states or Canadian provinces do not allow limitations on how long an implied warranty lasts, or the limitation or exclusions of consequential or incidental damages, so the foregoing exclusions and limitations may not apply to you. This warranty gives you specific legal rights, and you may also have other rights which vary from state to state and from Canadian province to Canadian province.