

Engineering Specification

W-235-H-X-*S-PP (*Non-reversing*)

W-235-HAC-X-*S-PP (*Reversing*)

Commercial Water to Water Heat Pump / Chiller

Single Compressor, R454b, 60 Hz

Heating/Cooling or Dedicated Domestic Hot Water Application

Nominal Size 20 Ton



Maritime Geothermal Ltd.
P.O. Box 2555, 170 Plantation Road
Petitcodiac, NB E4Z 6H4
(506) 756-8135

info@nordicghp.com
www.nordicghp.com
002776SPC-01

Model Nomenclature

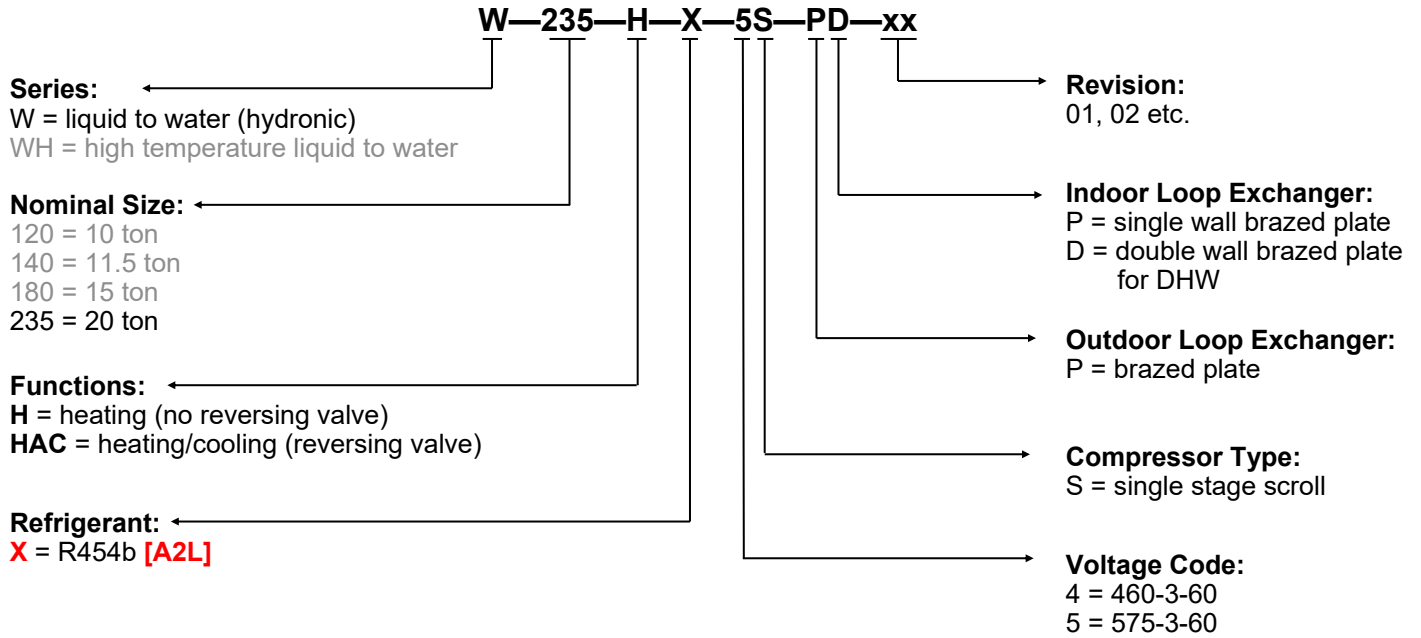

APPLICATION TABLE										
MODEL	FUNCTION	REFRIGERANT	VOLTAGE	COMPRESSOR	OUTDOOR COIL	INDOOR COIL	REVISIONS			
W-235	H	X	4 5	S	P	P D	01			
	HAC	X	4 5	S	P	P	01			

This manual applies only to the models and revisions listed in this table.

Maritime Geothermal Ltd. has a continuous improvement policy and reserves the right to modify specification data at any time without prior notice .

Design Features

- R454b refrigerant (GWP=466) is climate change-friendly. Note that R454b has an **A2L** classification.
- Indoor loop water heating to 130°F / 54°C, at typical geothermal ground loop temperatures
- Direct domestic hot water heating with the *double wall condenser* option; at reduced condenser flow rate, up to final plumbing code temperature of 140°F / 60°C (see Application, Installation, & Service Manual)
- TUV listed for electrical certification (CSA/UL equivalent)
- 16 gauge heavy duty cabinet with 4-side access for fork lift
- Insulated heat exchangers and piping
- Single refrigeration circuit, with minimum-volume design for superior oil management
- Optional 4-way reversing valve, for space heating/cooling applications
- Advanced dual-shell Bitzer scroll compressor
- Suction and discharge vibration absorbers
- Suction line accumulator, for compressor liquid protection
- Liquid line solid core filter-dryer
- Liquid line sight glass
- Electronic Expansion Valve (EEV) with built in sight glass
- Refrigeration service ports for each refrigeration circuit (1/4" Schrader)
- 316 stainless steel brazed plate heat exchangers, with optional double-wall indoor loop brazed plate condenser for dedicated domestic hot water heating duty
- 316 stainless piping with 2" Victaulic connections for the outdoor and indoor loops
- 3-phase protection
- High and low pressure sensors
- Suction line temperature sensor
- Manual reset high pressure control
- Flow switch is standard equipment for outdoor loop, and also for indoor loop on reversing units (-HAC)
- Temperature sensor and P/T port on all four water lines (Outdoor In, Outdoor Out, Indoor In and Indoor Out)
- Advanced control board with BACNet interface for remote operation and data access including all sensor data and alarm conditions, PWM outputs (or 0-10VDC), configurable analog inputs (0-10VDC or 4-20mA) with on board 5VDC, 12VDC and 24VDC power supplies.
- USB port for complete data access using Windows laptop computer and provided software; including real-time charting, data logging, and diagnostic functionality with manual override operation
- 2 x 16 LCD display for control and data access
- Random start on power up (0-2 minutes)
- Dry contacts for external pump control signal (24VAC 5A MAX)

Available Accessories

- Outdoor temperature sensor with enclosure, for outdoor reset functionality
- Tank temperature sensor(s) for standalone configuration
- Factory headers for multiple units

Design Features

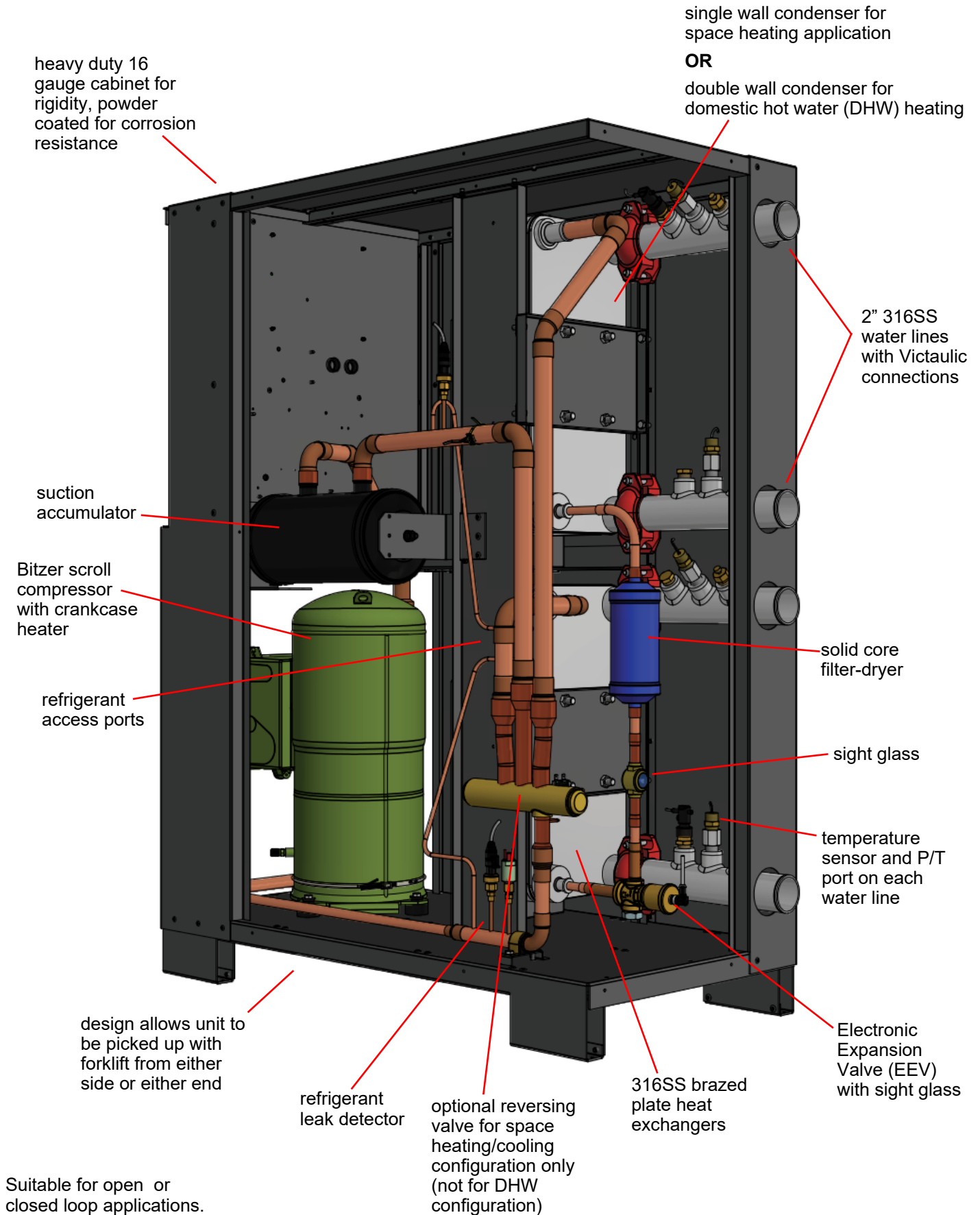

Design Features

multiple units may be installed
with no side clearance, with
headers horizontal

heavy duty 16
gauge cabinet for
rigidity, powder
coated for corrosion
resistance



end access:
piping connections,
line components

LCD interface &
USB port

completely insulated
with 1" acoustic
insulation



no side
access
required

end access:
compressor,
electric box

Dimensions

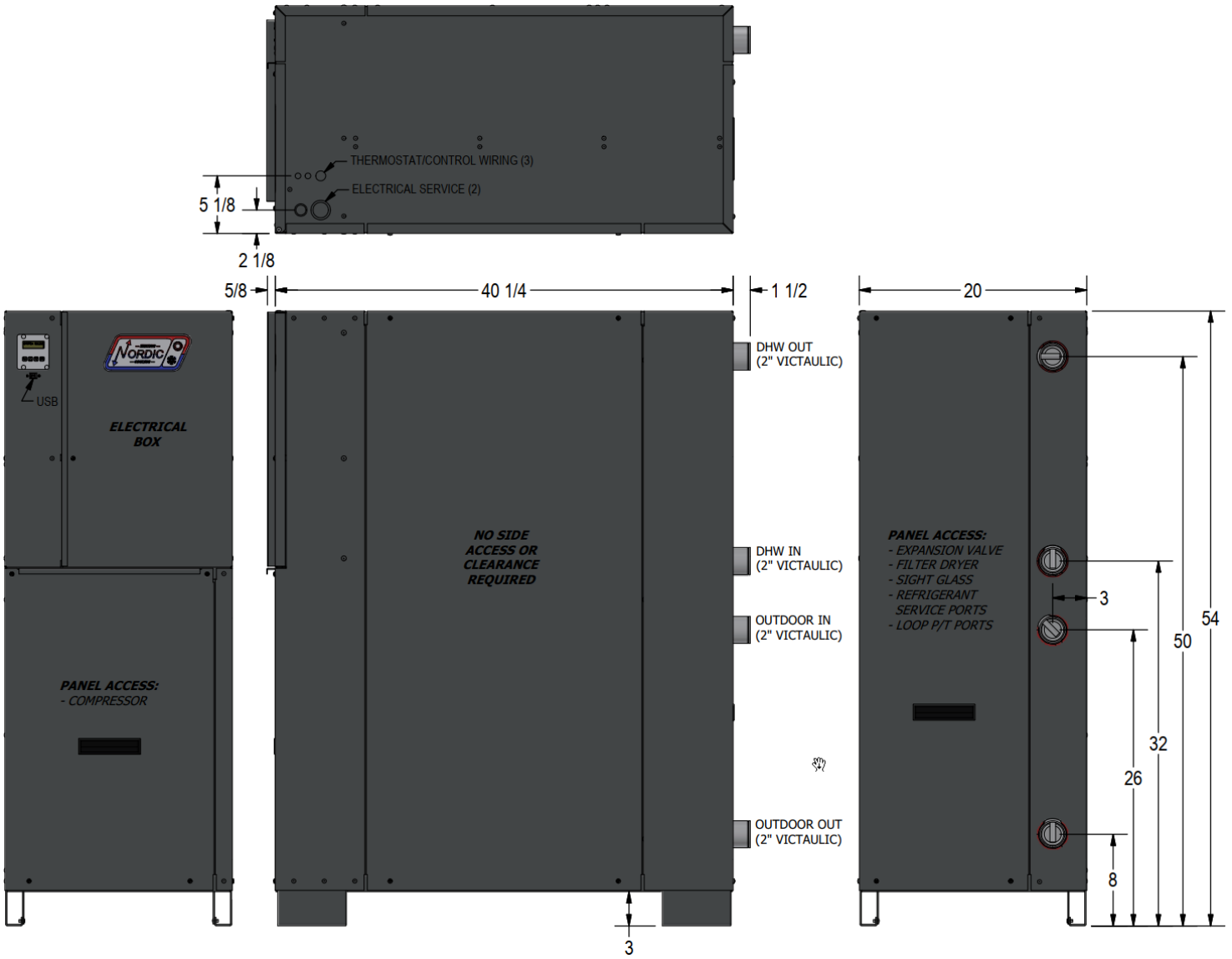

RECOMMENDED
FRONT CLEARANCE:
3 FT

NO SIDE CLEARANCE REQUIRED

RECOMMENDED
BACK CLEARANCE:
3 FT + HEADERS

All dimensions in inches.

Specifications

Electrical Specifications (R454b)										
MODEL	Nomenclature Identifier	Power Supply			Compressors (each)		FLA	MCA	Maximum Fuse/Breaker	Minimum Wire Size
		V- ϕ -Hz	MIN	MAX	RLA	LRA	Amps	Amps	Amps	ga
W-235	4	460-3-60	414	506	32.1	211	32.6	40.6	60	#6-3
	5	575-3-60	518	632	27.8	162	28.3	35.3	60	#6-3

Refrigerant Charge				
MODEL	TYPE	lb	kg	OIL
W-235	R454b	21.5	9.8	PVE-BVC32

- Oil capacity is marked on the compressor label.
 - Refrigerant charge is **subject to revision; actual charge is indicated on the unit nameplate.**

Shipping Information				
MODEL	WEIGHT lb. (kg)	DIMENSIONS in (cm)		
		L	W	H
W-235	959 (436)	60 (152)	30 (76)	60 (152)

Standard Capacity Ratings - Ground Loop Heating* 60Hz						
EWT 104°F (40°C)				ELT 32°F (0°C)		
MODEL	Liquid Flow (Outdoor & Indoor)		Input Energy Watts	Capacity		COP _H W/W
	gpm	L/s		Btu/hr	kW	
W-235	60	3.8	15,284	177,100	52	3.40

* 35% Propylene Glycol by Volume Outdoor (Ground) Loop Fluid

Standard Capacity Ratings - Ground Water Heating 60Hz						
EWT 104°F (40°C)				ELT 50°F (10°C)		
MODEL	Liquid Flow (Outdoor & Indoor)		Input Energy Watts	Capacity		COP _H W/W
	gpm	L/s		Btu/hr	kW	
W-235	60	3.8	15,794	243,700	71	4.52

Standard Capacity Ratings - Ground Loop Cooling* 60Hz							
EWT 53.6°F (12°C)				ELT 77°F (25°C)			
MODEL	Liquid Flow (Outdoor & Indoor)		Input Energy Watts	Evap. Capacity		COP _c W/W	EER Btu/hr/W
	gpm	L/s		Btu/hr	kW		
W-235	60	3.8	14,037	213,400	63	4.45	15.2

* 35% Propylene Glycol by Volume Outdoor (Ground) Loop Fluid

Standard Capacity Ratings - Ground Water Cooling 60Hz							
EWT 53.6°F (12°C)				ELT 59°F (15°C)			
MODEL	Liquid Flow (Outdoor & Indoor)		Input Energy Watts	Evap. Capacity		COP _c W/W	EER Btu/hr/W
	gpm	L/s		Btu/hr	kW		
W-235	60	3.8	10,766	228,200	67	6.21	21.2

Specifications

Recommended Flow Rates						
MODEL	OUTDOOR LOOP		INDOOR LOOP (MAX. 130°F)		INDOOR LOOP (DHW to 140°F)	
	gpm(US)	L/s	gpm(US)	L/s	gpm(US)	L/s
W-235	60	3.8	60	3.8	35	2.2

Heat Pump Holdup Volumes						
MODEL	OUTDOOR LOOP		INDOOR LOOP (SINGLE WALL '-PP')		INDOOR LOOP (DOUBLE WALL '-PD')	
	US gal	L	US gal	L	US gal	L
W-235	3.70	14.0	3.70	14.0	4.39	16.6

W-SERIES Operating Temperature Limits					
Loop	Mode	Parameter	(°F)	(°C)	Note
Indoor Loop	HEATING (indoor is hot loop)	Minimum ELT/EWT	50	10	0-10VDC modulating water valve required on indoor loop at temperatures < 80°F (27°C), or manual flow reduction at startup
		Maximum LLT/LWT	130	54	
		Maximum LLT/LWT	140	60	Domestic hot water (DHW) heating with double wall condenser option and reduced flow rate.
	COOLING (reversing HAC units only, indoor is cold loop)	Minimum LWT	40	4	Indoor loop with water only (no antifreeze).
		Minimum LLT	-->	-->	Indoor loop with antifreeze: depends on antifreeze type & %
		Maximum ELT	80	27	0-10VDC modulating water valve required on indoor loop above this temperature, or manual flow reduction at startup
Outdoor Loop	HEATING (outdoor is cold loop)	Minimum LWT	37	3	For water loops without antifreeze, e.g. open loop systems
		Minimum LLT	-->	-->	Ground loop system: depends on antifreeze type and % settings.
		Maximum ELT/EWT	80	27	0-10VDC modulating water valve required on outdoor loop above this temperature to limit suction pressure
	COOLING (reversing HAC units only, outdoor is hot loop)	Minimum ELT/EWT	50	10	0-10VDC modulating water valve required on outdoor loop at temperatures < 80°F (27°C) to keep head pressure up
		Maximum LLT/LWT	130	54	

ELT: Entering Liquid Temperature (implies antifreeze present)
 LLT: Leaving Liquid Temperature (implies antifreeze present)
 EWT: Entering Water Temperature
 LWT: Leaving Water Temperature
 Values in these tables are for rated liquid and water flows.

Specifications

Pressure Drop Data (US UNITS)

		<i>OUTDOOR LOOP & INDOOR LOOP w/ SINGLE WALL OPTION</i>					<i>INDOOR LOOP w/ DOUBLE WALL OPTION</i>	
		water 130°F	water 104°F	water 50°F	15% methanol 32°F	35% prop. glycol 32°F	DHW 140°F	DHW 50°F
W-235	USgpm	psi	psi	psi	psi	psi	psi	psi
	35	0.8	0.9	0.9	1.2	1.3	1.0	1.1
	40	1.1	1.1	1.1	1.5	1.7	1.3	1.4
	45	1.4	1.4	1.4	1.9	2.1	1.6	1.7
	50	1.7	1.7	1.8	2.3	2.5	2.0	2.1
	55	2.0	2.0	2.1	2.7	3.0	2.4	2.6
	60	2.4	2.4	2.5	3.2	3.5	2.9	3.0
	65	2.8	2.8	2.9	3.7	4.0	3.4	3.6

METRIC

Pressure Drop Data (METRIC UNITS)

		<i>OUTDOOR LOOP & INDOOR LOOP w/ SINGLE WALL OPTION</i>					<i>INDOOR LOOP w/ DOUBLE WALL OPTION</i>	
		water 130°F	water 104°F	water 50°F	15% methanol 32°F	35% prop. glycol 32°F	DHW 140°F	DHW 50°F
W-235	L/s	kPa	kPa	kPa	kPa	kPa	kPa	kPa
	2.2	6	6	6	8	9	7	7
	2.5	7	8	8	11	12	9	10
	2.8	9	10	10	13	14	11	12
	3.2	11	12	12	16	17	14	15
	3.5	14	14	15	19	21	17	18
	3.8	16	17	17	22	24	20	21
	4.1	19	19	20	26	28	23	25

Performance Tables - W-Series (US UNITS)

W-235-H**-X*-S-P* R454b, 60 Hz, GSD60235VL (460-3-60)

*Compressor current is for 460-3-60.
Multiply by 0.8 for 575-3-60.

	EVAPORATOR LOOP (35% Propylene Glycol)						ELECTRICAL		CONDENSER LOOP (Water)							
	ELT (°F)	Evap. Temp.	Flow (gpm)	LLT (°F)	Delta T (°F)	Heat Abs. (Btu/hr)	Compressor Current (A)*	Input Power (W)	EWT (°F)	Cond. Temp.	Flow (gpm)	LWT (°F)	Delta T (°F)	Heating (Btu/hr)	COP _H	
HEATING	25	15	60	21	-3.8	105,700	22.2	15,126	104		114	60	109	5.2	156,200	3.03
	30	19	60	26	-4.3	120,000	22.3	15,232		115	60	110	5.7	170,900	3.29	
	35	24	60	30	-4.9	135,400	22.4	15,357		115	60	110	6.3	186,800	3.56	
	40	29	60	35	-5.5	152,300	22.6	15,476		116	60	111	6.8	204,100	3.87	
	45	34	60	39	-6.1	170,700	22.8	15,630		117	60	112	7.5	223,100	4.18	
	50	38	60	43	-6.8	190,700	23.0	15,794		117	60	112	8.2	243,700	4.52	
	55	43	60	47	-7.6	212,100	23.2	15,989		118	60	113	8.9	265,800	4.87	
	60	48	60	52	-8.4	235,600	23.5	16,243		118	60	114	9.7	290,200	5.24	
	65	52	60	56	-9.3	261,100	23.9	16,531		119	60	115	10.6	316,700	5.61	
	70	57	60	60	-10.3	288,500	24.3	16,891		120	60	116	11.6	345,300	5.99	
	25	15	60	22	-3.5	96,400	24.0	16,748		115	124	60	120	5.1	152,400	2.67
	30	20	60	26	-4.0	110,100	24.2	16,882		114	124	60		5.6	166,600	2.89
	35	24	60	31	-4.5	125,100	24.4	17,003		114	124	60		6.1	182,100	3.14
	40	29	60	35	-5.1	141,800	24.6	17,155		113	125	60		6.7	199,300	3.40
45	34	60	39	-5.7	159,900	24.8	17,309	113	125	60	7.3	218,000		3.69		
50	39	60	44	-6.4	179,600	25.1	17,511	112	125	60	8.0	238,400		3.99		
55	43	60	48	-7.2	201,100	25.4	17,731	111	125	60	8.8	260,700		4.31		
60	48	60	52	-8.0	224,500	25.8	18,014	110	126	60	9.6	285,100		4.64		
65	53	60	56	-8.9	250,100	26.2	18,332	110	126	60	10.5	311,800		4.98		
70	57	60	60	-9.9	277,600	26.7	18,730	109	126	60	11.5	340,700		5.33		
DHW	25	12	60	22	-3.4	95,400	31.8	22,411	130	138	35	140 (DHW)		9.9	170,800	2.23
	30	17	60	26	-3.8	106,800	31.0	21,851	130	138	35			10.5	180,300	2.42
	35	22	60	31	-4.3	119,400	30.2	21,286	129	138	35			11.1	191,000	2.63
	40	27	60	35	-4.8	132,900	29.3	20,701	128	139	35			11.7	202,600	2.87
	45	32	60	40	-5.3	147,700	28.5	20,153	128	139	35		12.5	215,500	3.13	
	50	37	60	44	-5.8	163,300	27.8	19,622	127	139	35		13.3	229,400	3.43	
	55	42	60	49	-6.4	180,200	27.0	19,116	126	139	35		14.2	244,600	3.75	
	60	47	60	53	-7.1	198,900	26.3	18,640	125	140	35		15.2	261,700	4.11	
	65	51	60	57	-7.8	218,800	25.6	18,171	124	140	35		16.2	280,000	4.52	
70	56	60	61	-8.6	240,400	25.0	17,762	123	140	35	17.4	300,200	4.95			

	EVAPORATOR LOOP (Water)						ELECTRICAL		CONDENSER LOOP (35% Propylene Glycol)						
	ELT (°F)	Evap. Temp.	Flow (gpm)	LLT (°F)	Delta T (°F)	Cooling (Btu/hr)	Compressor Current (A)*	Input Power (W)	EWT (°F)	Cond. Temp.	Flow (gpm)	LWT (°F)	Delta T (°F)	Heat Rej. (Btu/hr)	EER
COOLING	54	34	60	46	-7.8	235,100	15.7	9,415	50	73	60	60	9.5	266,200	25.0
		35	60	46	-7.7	231,600	16.6	10,146	55	78	60	65	9.5	265,300	22.8
		36	60	46	-7.6	227,500	17.6	10,932	60	83	60	69	9.4	263,900	20.8
		36	60	46	-7.5	223,700	18.6	11,763	65	88	60	74	9.4	263,000	19.0
		37	60	46	-7.3	219,400	19.7	12,666	70	94	60	79	9.3	261,800	17.3
		37	60	46	-7.2	215,200	20.9	13,629	75	99	60	84	9.3	261,000	15.8
		38	60	47	-7.0	210,500	22.2	14,682	80	104	60	89	9.2	259,900	14.3
		38	60	47	-6.9	206,000	23.6	15,811	85	109	60	94	9.2	259,300	13.0
		39	60	47	-6.7	200,900	25.2	17,052	90	115	60	99	9.2	258,500	11.8
		39	60	47	-6.5	195,900	26.9	18,387	95	120	60	104	9.2	258,100	10.7

Performance Tables - W-Series (METRIC UNITS)

W-235-H**-X-*S-P* R454b, 60 Hz, GSD60235VL (460-3-60)

*Compressor current is for 460-3-60. Multiply by 0.8 for 575-3-60.

METRIC

	EVAPORATOR LOOP (35% Propylene Glycol)						ELECTRICAL		CONDENSER LOOP (Water)						
	ELT (°C)	Evap. Temp.	Flow (L/s)	LLT (°C)	Delta T (°C)	Heat Abs. (kW)	Compressor Current (A)*	Input Power (W)	EWT (°C)	Cond. Temp.	Flow (L/s)	LWT (°C)	Delta T (°C)	Heating (kW)	COP _H
HEATING	-3.9	-9.6	3.8	-6.0	-2.1	31.0	22.2	15,126	40	45.5	3.8	42.9	2.9	45.8	3.03
	-1.1	-7.0	3.8	-3.5	-2.4	35.2	22.3	15,232		45.8	3.8	43.2	3.2	50.1	3.29
	1.7	-4.4	3.8	-1.0	-2.7	39.7	22.4	15,357		46.2	3.8	43.5	3.5	54.8	3.56
	4.4	-1.8	3.8	1.3	-3.1	44.6	22.6	15,476		46.6	3.8	43.8	3.8	59.8	3.87
	7.2	0.8	3.8	3.8	-3.4	50.0	22.8	15,630		46.9	3.8	44.2	4.2	65.4	4.18
	10.0	3.4	3.8	6.2	-3.8	55.9	23.0	15,794		47.3	3.8	44.6	4.6	71.4	4.52
	12.7	6.0	3.8	8.5	-4.2	62.2	23.2	15,989		47.6	3.8	44.9	4.9	77.9	4.87
	15.5	8.6	3.8	10.8	-4.7	69.1	23.5	16,243		48.0	3.8	45.4	5.4	85.1	5.24
	18.3	11.2	3.8	13.1	-5.2	76.5	23.9	16,531		48.3	3.8	45.9	5.9	92.8	5.61
	21.1	13.8	3.8	15.4	-5.7	84.6	24.3	16,891		48.7	3.8	46.4	6.4	101.2	5.99
	-3.9	-9.5	3.8	-5.8	-1.9	28.3	24.0	16,748	46.1	51.0	3.8	49	2.8	44.7	2.67
	-1.1	-6.9	3.8	-3.3	-2.2	32.3	24.2	16,882	45.8	51.2	3.8		3.1	48.8	2.89
	1.7	-4.3	3.8	-0.8	-2.5	36.7	24.4	17,003	45.5	51.3	3.8		3.4	53.4	3.14
	4.4	-1.6	3.8	1.6	-2.8	41.6	24.6	17,155	45.2	51.4	3.8		3.7	58.4	3.40
	7.2	1.0	3.8	4.0	-3.2	46.9	24.8	17,309	44.8	51.6	3.8		4.1	63.9	3.69
	10.0	3.6	3.8	6.4	-3.6	52.6	25.1	17,511	44.4	51.7	3.8		4.4	69.9	3.99
	12.8	6.2	3.8	8.8	-4.0	58.9	25.4	17,731	44.0	51.8	3.8		4.9	76.4	4.31
	15.6	8.8	3.8	11.2	-4.4	65.8	25.8	18,014	43.6	52.0	3.8		5.3	83.6	4.64
	18.3	11.4	3.8	13.4	-4.9	73.3	26.2	18,332	43.1	52.1	3.8		5.8	91.4	4.98
	21.1	14.1	3.8	15.6	-5.5	81.4	26.7	18,730	42.5	52.3	3.8		6.4	99.9	5.33
DHW	-3.9	-11.2	3.8	-5.8	-1.9	28.0	31.8	22,411	54.5	58.7	2.2	60 (DHW)	5.5	50.1	2.23
	-1.1	-8.4	3.8	-3.2	-2.1	31.3	31.0	21,851	54.2	58.9	2.2		5.8	52.8	2.42
	1.7	-5.7	3.8	-0.7	-2.4	35.0	30.2	21,286	53.8	59.1	2.2		6.2	56.0	2.63
	4.4	-2.9	3.8	1.7	-2.7	39.0	29.3	20,701	53.5	59.2	2.2		6.5	59.4	2.87
	7.2	-0.2	3.8	4.3	-2.9	43.3	28.5	20,153	53.1	59.3	2.2		6.9	63.2	3.13
	10.0	2.6	3.8	6.8	-3.2	47.9	27.8	19,622	52.6	59.5	2.2		7.4	67.2	3.43
	12.8	5.3	3.8	9.2	-3.6	52.8	27.0	19,116	52.1	59.7	2.2		7.9	71.7	3.75
	15.6	8.1	3.8	11.7	-3.9	58.3	26.3	18,640	51.6	59.8	2.2		8.4	76.7	4.11
	18.3	10.8	3.8	14.0	-4.3	64.1	25.6	18,171	51.0	59.9	2.2		9.0	82.1	4.52
	21.1	13.6	3.8	16.3	-4.8	70.5	25.0	17,762	50.3	60.1	2.2		9.7	88.0	4.95

	EVAPORATOR LOOP (Water)						ELECTRICAL		CONDENSER LOOP (35% Propylene Glycol)						
	ELT (°C)	Evap. Temp.	Flow (L/s)	LLT (°C)	Delta T (°C)	Cooling (kW)	Compressor Current (A)*	Input Power (W)	EWT (°C)	Cond. Temp.	Flow (L/s)	LWT (°C)	Delta T (°C)	Heat Rej. (kW)	COP _C
COOLING	12	1	3.8	7.7	-4.3	68.9	15.7	9,415	10.0	23	3.8	15.3	5.3	78.0	7.33
		2	3.8	7.7	-4.3	67.9	16.6	10,146	12.8	25	3.8	18.1	5.3	77.8	6.68
		2	3.8	7.8	-4.2	66.7	17.6	10,932	15.6	28	3.8	20.8	5.2	77.3	6.10
		2	3.8	7.8	-4.2	65.6	18.6	11,763	18.3	31	3.8	23.5	5.2	77.1	5.57
		3	3.8	7.9	-4.1	64.3	19.7	12,666	21.1	34	3.8	26.3	5.2	76.7	5.07
		3	3.8	8.0	-4.0	63.1	20.9	13,629	23.9	37	3.8	29.1	5.2	76.5	4.63
		3	3.8	8.1	-3.9	61.7	22.2	14,682	26.7	40	3.8	31.8	5.1	76.2	4.19
		4	3.8	8.2	-3.8	60.4	23.6	15,811	29.4	43	3.8	34.5	5.1	76.0	3.81
		4	3.8	8.3	-3.7	58.9	25.2	17,052	32.2	46	3.8	37.3	5.1	75.8	3.46
		4	3.8	8.4	-3.6	57.4	26.9	18,387	35.0	49	3.8	40.1	5.1	75.6	3.14

W/WH-Commercial Schematic Diagram - Single Circuit / Single Compressor (-H/HAC)

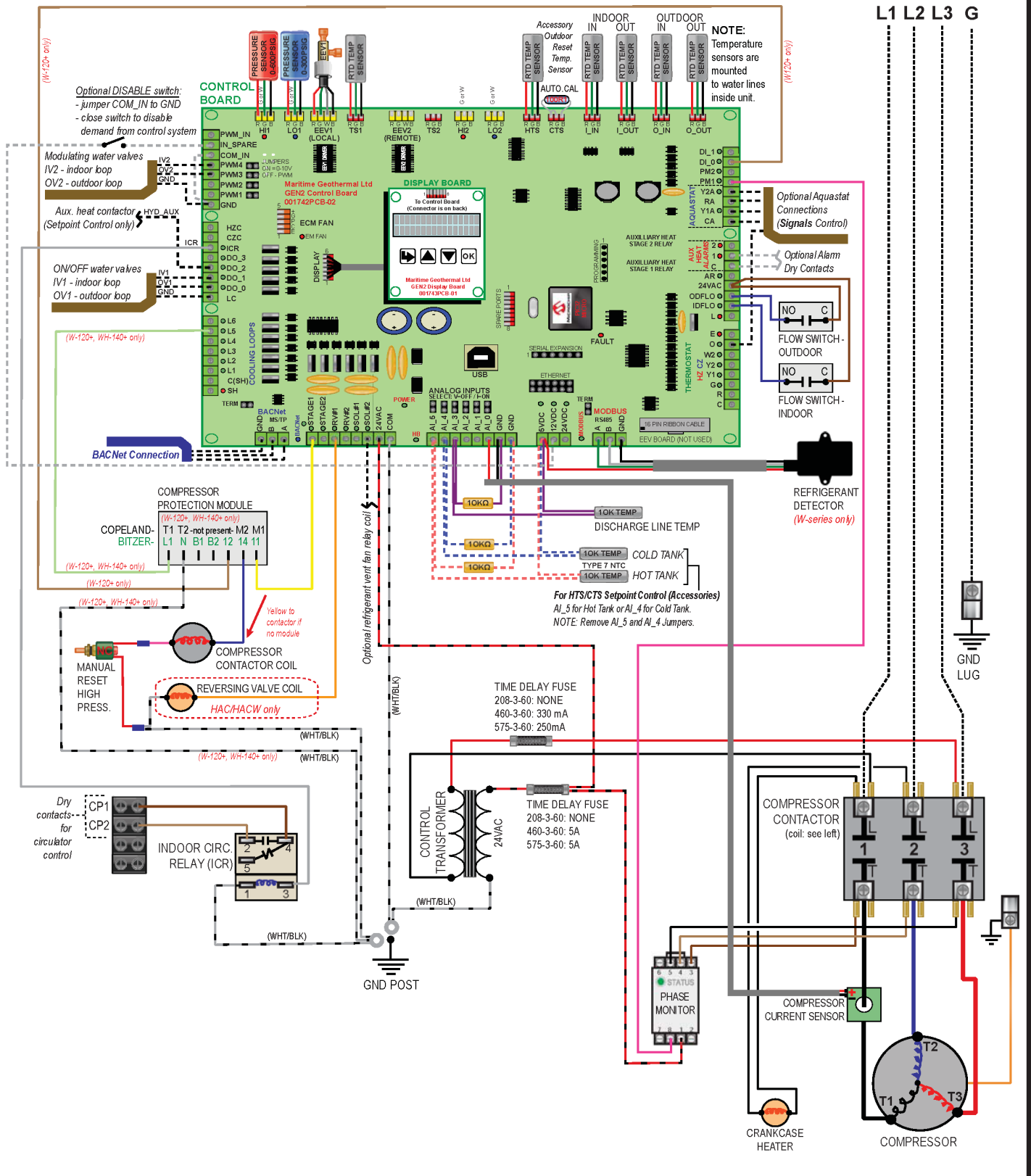

Drawn By D. RHEAULT	Date 23-SEP-2024		P.O. Box 2555 170 Plantation Rd. Pettitcodiac, NB CANADA E4Z 6H4
Checked By D. RHEAULT	Date 23-SEP-2024		
Eng. Approved By	Date	Drawing Name	
Mfg. Approved By	Date	W/WH-Single Compressor Schematic Diagram (-H/HAC)	
Approved By	Date	Size LET	Drawing Number 002753SCH
		Drawing Rev 01	Sheet 1 / 1

W/WH Commercial Single Compressor Electrical Box Diagram



DANGER: HIGH VOLTAGE.
Ensure power is off before opening the electrical box cover.

Control Wiring Power Wiring
GND L1 L2 L3

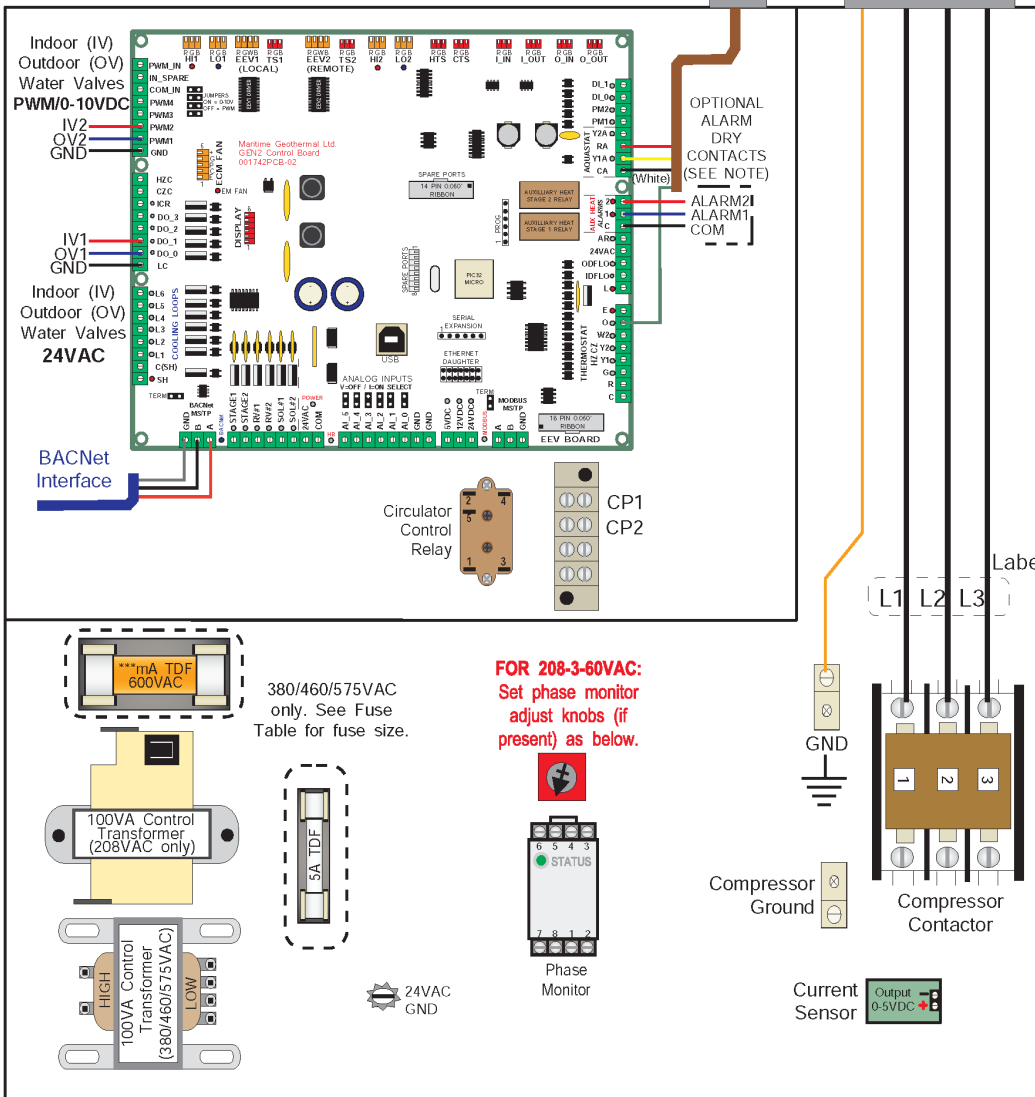

FUSE TABLE ***	
Supply Voltage	Fuse Value*
208-3-60	-----
460-3-60	330mA
575-3-60	250mA
380-3-50	500mA

CONTROL CONNECTIONS (HARDWIRED OPTION)

- RA(24VAC)
- Y1A(Compressor #1)
- CA(Common)
- O(Cooling - HAC only)

*Value is marked in electrical box.

Use PC App or LCD menus to select 1 of 3 Control Methods:

1. BACnet
2. Hardwired (24VAC signals)
3. Setpoint Control (internal)

1. BACnet (MS/TP RS-485)

Use twisted pair shielded-conductor cable.
A - Communication
B - Communication
GND - Ground

SYSTEM_Y1A: Stage 1 (compr.1)
SYSTEM_O: Htg/Cooling Mode (active in cooling - HAC only)

2. Hardwired/Signals (24VAC)

Use an 18-3 or 18-4 cable.
C - 24VAC Common
R - 24VAC Hot
Y1A - Stage 1 (Compressor 1)
O - Heating/Cooling Mode (active for cooling mode - HAC only)

A dry contact from R to Y1A will start compressor.

A dry contact from R to O will activate cooling mode (HAC only)

3. Setpoint Control

Unit will be controlled by internal water line temperature sensors. See manual for setup instructions.

IMPORTANT NOTES:

- **3 PHASE SCROLL COMPRESSORS** must rotate in the proper direction. After the initial connection, if the phase protection module(s) indicate a fault on power up, turn the power off and reverse the L1 and L2 supply leads. Turn the power on and clear the fault(s).
- **IMPORTANT:** Ensure sufficient antifreeze concentration is used and correctly set in control board via the PC App, so that the correct low pressure cutout value is implemented to prevent freezing conditions. Failure to do so could cause the heat exchanger to freeze and rupture, voiding the warranty.

- **Anti-short cycle timer** of 6 minutes.
- **Alarm1** signal is dry contacts (NO). Connect the signal source to COM. **MAX 1amp @ 24VAC**
- **CP1 and CP2** are a dry contact that can be used to turn on circulator pumps when either compressor starts. In Setpoint Control mode, it is indoor circulators only (sampling). **MAX 5amps @ 24VAC**
- **Water Valve:** 24VAC is present across OV1/IV1 and GND to power an external ON/OFF water valve when either compressor starts. Modulating water valves can be connected between OV2/IV2 and GND. **MAX 1amp @ 24VAC**

					Drawn By Chris Geddes	Date 28-JUN-2019	MARITIME GEOTHERMAL LTD. 170 Plantation Rd. Petitcodiac, NB E4Z 6H4
					Checked By Chris Geddes	Date 28-JUN-2019	
01	ISSUE 02	D. RHEAULT	D. RHEAULT	15-Mar-2022	Approved By (ENG) Chris Geddes	Date 28-JUN-2019	Drawing Name W-WH-Commercial Single Compressor Electrical Box Diagram
01	Initial Release	C. GEDDES	C. GEDDES	28-JUN-2019	Approved By (MFG)	Date	Size A
REV	ECO #	IMPL BY	APVD BY	DATE	Approved By	Date	Drawing Number 002400ELB
							Drawing Rev 01(i2)
							SHEET 1 of 1

Refrigeration Circuit Diagram: Non-Reversing Model

W/WH-H Heating Mode

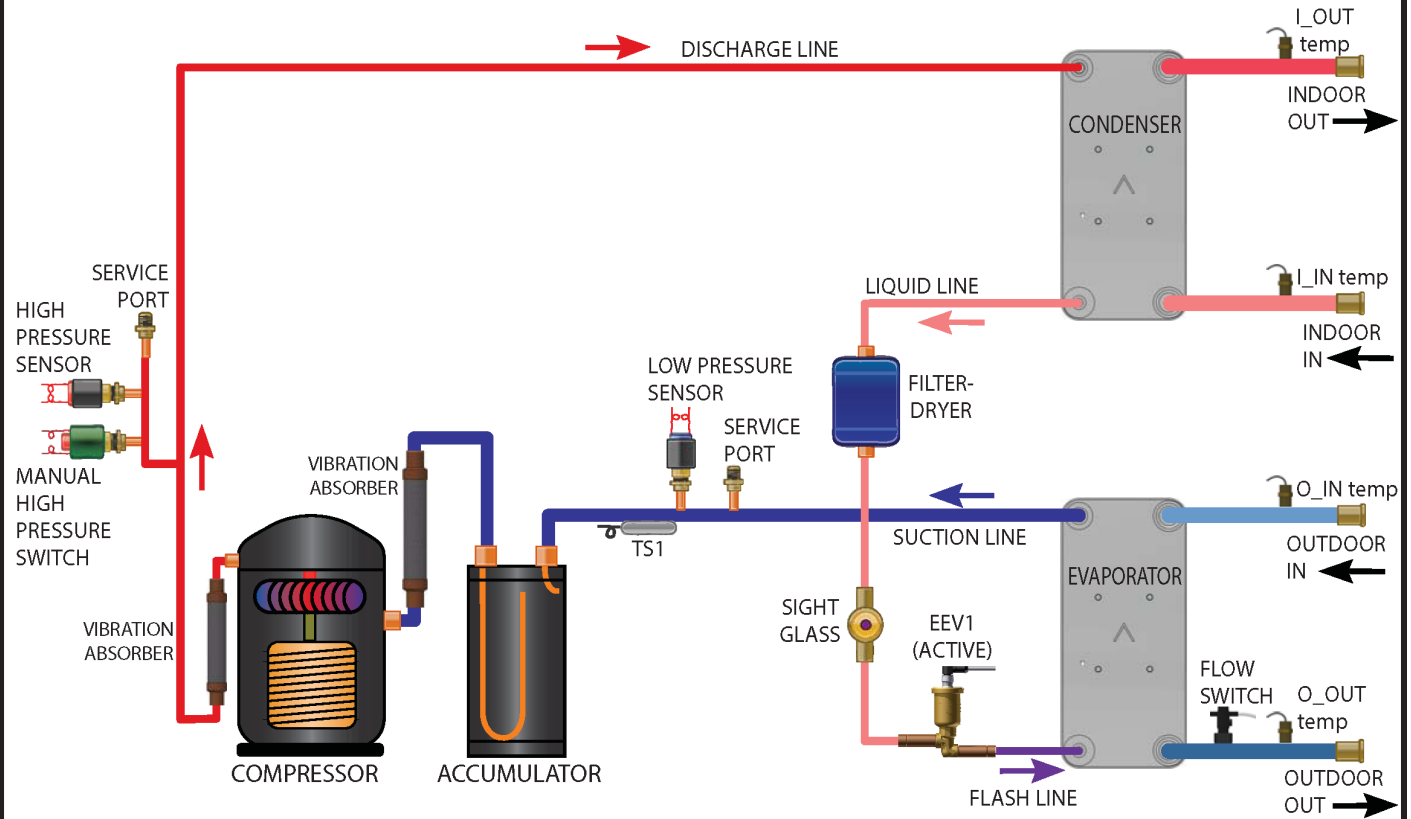

					Drawn By D. RHEAULT Date 15-JUL-2019	MARITIME GEOTHERMAL LTD. P.O. Box 2555 170 Plantation Rd. Petitcodiac, NB CANADA E4Z 6H4		
					Checked By D. RHEAULT Date 15-JUL-2019			
					Eng. Approved By D. RHEAULT Date 15-JUL-2019	Drawing Name W/WH-H Refrigeration Circuit (Single Compressor, Brazed Plates, Non-Reversing)		
01	ISSUE 02	D. RHEAULT	D. RHEAULT	19-JUN-2023	Mfg. Approved By	Date		
01	Initial Release	D. RHEAULT	D. RHEAULT	15-JUL-2019	Approved By	Date		
REV	ECO#	IMPL BY	APVD BY	DATE	Size	Drawing Number	Drawing Revision	Sheet
					LET	002403RCD	01(i2)	1 / 1

Refrigeration Circuit Diagram: Reversing Model

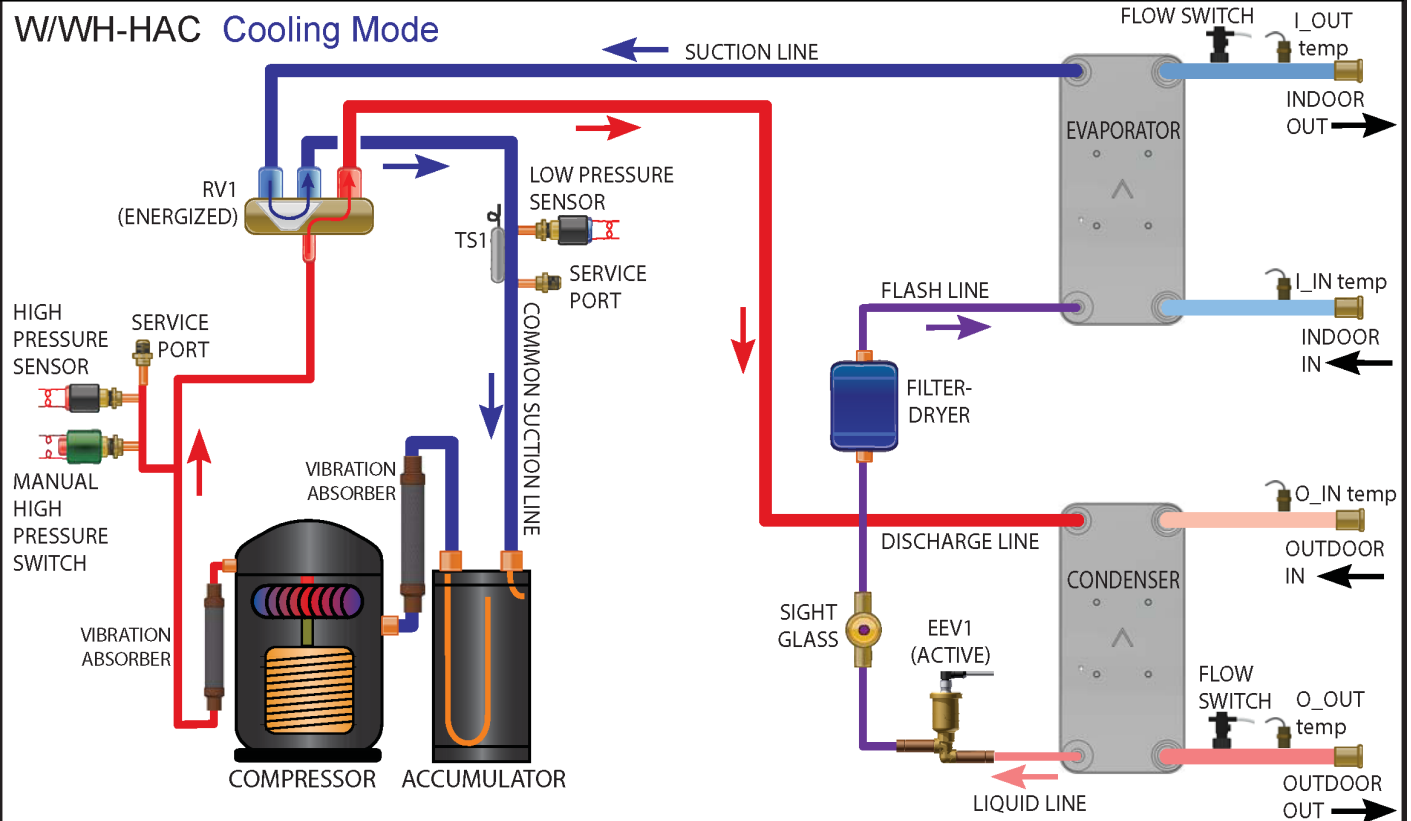
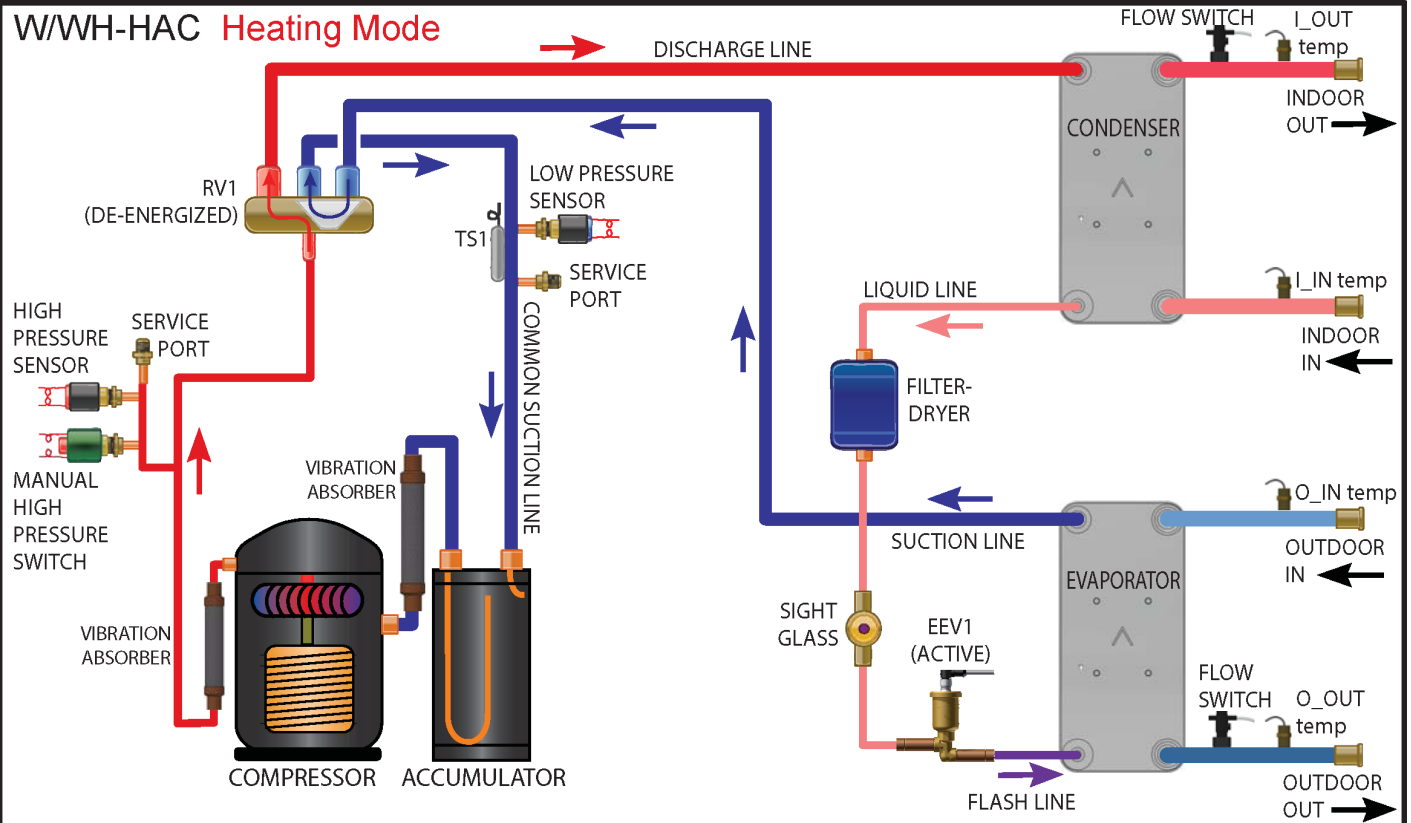

01	Initial Release	D. RHEAULT	D. RHEAULT	19-JUN-2023	Drawn By Dan Rheault Date 19-JUN-2023 Checked By Dan Rheault Date 19-JUN-2023 Eng. Approved By Dan Rheault Date 19-JUN-2023 Mfg. Approved By Date Approved By Date	Date 19-JUN-2023 Date 19-JUN-2023 Date 19-JUN-2023 Date	MARITIME GEOTHERMAL LTD. P.O. Box 2555 170 Plantation Rd. Petitcodiac, NB CANADA E4Z 6H4	Drawing Name W/WH-HAC Refrigeration Circuit (Single Compressor, Brazed Plates, Reversing)	Size LET	Drawing Number 002644RCD	Drawing Revision 01	Sheet 1 / 1
----	-----------------	------------	------------	-------------	--	---	--	--	-------------	-----------------------------	------------------------	----------------

BACnet Interface

The BACnet interface is an **MS/TP** connection via RS-485 twisted pair. BACnet **IP** is not available.
Recommended wire: 22-24 AWG single twisted pair, 100-120 Ohms impedance, 17pF/ft or lower capacitance, with braided or aluminum foil shield, such as Belden 9841 or 89841.

The connector on the control board is a three wire removable screw connector. The signals are as follows:

- A: Communications line (+) (right pin)
- B: Communications line (-) (middle pin)
- C: Ground connection (left pin)

If connecting multiple units to one RS-485 connection point, connect the signal cable from the master building controller to the first unit. Connect the second unit to the first unit (in same connector), connect the third unit to the second unit, and so on until all units are connected (daisy-chain). Remove the TERM jumper (located just above the BACnet connector on control board) from all units except the last one. The shield ground should be connected only to the GND pin of the unit for single unit installations. For multiple units, the shield ground should only be connected to the GND pin of the last unit. The shield grounds for intermediate units should be connected together. The shield ground should be left unconnected at the building controller end for all cases.

Vendor: Maritime Geothermal Ltd.
Vendor ID: 260
Model Name: MGT GEN2 Control Board

The following parameters can be set via the PC App's *Configuration Window*:

- 1) **Baud rate**
9600, 19200, 38400, or 76800
- 2) **MAC address**
Maximum value is 125.
- 3) **Instance number**
Maximum value is 4194303.

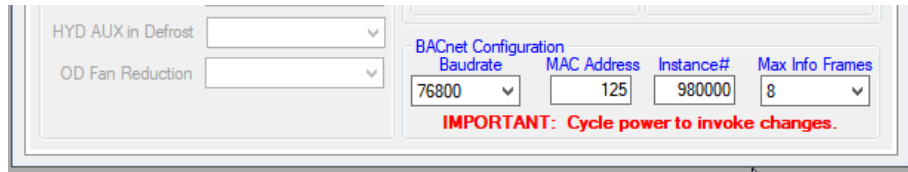

The BACnet parameter **Max_Master** has a fixed value of **127** in this device.

BACnet data is available regardless of the selected control method. In order to control the unit via the BACnet interface, set **Control Source** to **BACnet** either by using the PC App's configuration window or the LCD menus.

For tables listing BACnet objects, refer to **Application, Installation, and Service Manual**.

Engineering Guide Specifications

General

The liquid source water-to-water heat pump shall be a single packaged single refrigeration circuit heating / cooling unit. The unit shall be listed by a nationally recognized testing laboratory (NRTL), such as UL, CSA, TUV, or ETL. The unit shall be rated in accordance with applicable standards of the Air Conditioning, Heating, and Refrigeration Institute / International Standards Organization (AHRI/ISO) and/or Canadian Standards Association (CSA). The liquid source water to water heat pump, as manufactured by Maritime Geothermal Ltd. of Petitcodiac, New Brunswick, Canada shall be designed to operate correctly within liquid temperature ranges specified on the "Minimum and Maximum Operating Temperatures" page of this engineering specification document.

Factory Quality

Each unit shall be run tested at the factory with water circulating in both indoor and outdoor loops. Quality control system checks shall include: computerized nitrogen pressurized leak test, evacuation of refrigeration circuit to sustained vacuum, accurate system charge, detailed heating and cooling mode tests, and quality cross check all operational and test conditions to pass/fail criteria. Units tested without water flow are not acceptable. The units shall be warranted by the manufacturer against defects in materials and workmanship in accordance with the warranty section at the end of this document. Optional extended factory warranty coverage may be available.

Cabinet

Each unit shall be constructed in a heavy duty sheet metal cabinet. Cabinet shall be constructed of powder coated galvanized sheet metal of minimum 16 gauge. Sheet metal gauge shall be higher where structurally required. Design and construction of cabinet shall be such that it is rigid and passes the CSA/UL Loading Test requirements (200 lb roof test and 25 lb guard test). All panels shall be lined with minimum 1 inch [25.4 mm] thick acoustic type glass fiber insulation. All insulation shall meet the fire retardant provisions of NFPA 90A. This material shall also provide acoustical benefit. Cabinet must have a minimum of two end access panels for serviceability, with further panels removable as necessary for major service. The electrical box shall have separate holes and knockouts for entrance of line voltage and low voltage control wiring. All factory-installed wiring passing through factory knockouts and openings shall be protected from sheet metal edges at openings by plastic grommets.

Refrigerant Circuit

All units shall contain one sealed refrigerant circuit, containing a hermetic motor scroll compressor, one electronic expansion valve, factory installed high and low pressure safety controls or sensors, service ports, solid core filter-dryer, sight glass, reversing valve (for reversing units), and suction accumulator. Refrigerant circuit shall be of a minimum-volume design to ensure reliable oil management. To this end, units with receivers designed to hold the entire system charge are not acceptable.

Refrigerant used shall have a global warming potential (GWP) of less than 500. A refrigerant leak detector shall be factory installed.

Compressors shall be specified for heat pump duty with internal isolation consisting of rubber vibration isolators. Compressor motors shall have internal overload protection.

The water to refrigerant heat exchangers shall be of a stainless steel brazed plate design, designed and certified for 650 psig [4480 kPa] working pressure on the refrigerant side and 650 psig [4480 kPa] on the water side. Heat exchangers shall be insulated over all of their outside surface with minimum 3/8" thick closed cell insulation. Insulation consisting of 1/8" closed-cell insulating tape shall not be acceptable. A double wall condenser shall be available as a factory option for direct heating of domestic/potable water.

The electronic expansion valve shall be of a stepper-motor rather than pulsing type, and shall provide proper superheat control over the unit's operating range with minimal deviation from superheat setpoint. The valve shall be controlled by an electronic superheat controller which provides operator-adjustable superheat and real-time LED/LCD display of current superheat. Superheat shall be determined through the suction pressure-temperature method. Externally mounted pressure controlled water regulating flow valves or thermostatic expansion valves (TXV's) in place of electronic expansion valves are not acceptable.

The suction accumulator shall be insulated with minimum 3/8" thick closed cell insulation to prevent condensation. The accumulator's internal oil return port shall be sized properly for the unit's operating range. To ensure proper oil return, suction accumulator shall not be 'oversized'.

Piping and Connections

The unit shall have two sets of primary water in and water out connections (outdoor and indoor/DHW). The primary connection type shall be 2" stainless steel pipe for grooved/Victaulic connection.

All internal water and refrigerant piping shall be insulated with minimum 3/8" thick closed cell insulation. Insulation consisting of 1/8" closed-cell insulating tape shall not be acceptable.

Electrical

Controls and safety devices shall be factory wired and mounted within the unit. Controls shall include 24 volt alternating current (24VAC) activated compressor contactors, reversing valves, and 24VAC 100VA transformer with built in circuit breaker or fused on both primary and secondary sides. Units shall be name-plated for use with time delay fuses or circuit breakers. Unit controls shall be 24VAC and provide heating or cooling as required by the remote thermostat or controller. 3-phase protection shall be present in each unit to protect the compressor against loss of phase and reverse rotation. 3-phase protection shall be factory installed. Unit shall have dry contacts for controlling loop circulating pumps via an external 24VAC contactor. Unit shall provide remote fault indication to the control system via serial communication and fault messages on front panel LCD display.

Unit Control

The control system shall have the following features:

1. An on-board water temperature control routine using internal water line sensors and sampling via circulator control, so that external control is optional.
2. BACnet control, and also control by external dry contacts, as field alternatives to the above on-board routine.
3. Anti-short cycle time delay on compressor operation. Time delay shall be a minimum of 5 minutes, for both thermostat demand and safety control reset starts. An override shall be provided to disable this delay for unit commissioning and testing purposes.
4. Random compressor start delay of 0-120 seconds on unit power up to facilitate starting multiple units after a power failure.
5. Flow switch on outdoor loop, and also on indoor loop for reversing units.
6. Compressor shutdown for high or low refrigerant pressures, low flow conditions, and for phase protection faults.
7. Automatic intelligent reset: unit shall automatically restart 5 minutes after trip if the fault has cleared. Should a fault reoccur 3 times sequentially then permanent lockout shall occur, requiring cycling of the power to the unit in order to reset.
8. Manual reset high pressure in case of electronic board failure.
9. The low pressure shall not be monitored for the first 90 seconds after a compressor start to prevent nuisance safety trips.
10. 2 x 16 backlit Liquid Crystal Display (LCD) and four buttons for limited data access. Unit may be configured for stand alone operation with optional temperature sensor(s)
11. Universal Serial Bus (USB) port for full data access and diagnostic information, including real-time charting and data-logging

Maritime Geothermal works continually to improve its products. As a result, the design and specifications of any product may be changed without notice. Please contact Maritime Geothermal at 1-506-756-8135 or visit www.nordicghp.com for latest design and specifications. Purchaser's approval of this data set signifies that the equipment is acceptable under the provisions of the job specification. Statements and other information contained herein are not express warranties and do not form the basis of any commercial contract or other agreement between any parties, but are merely Maritime Geothermal's statement of opinion regarding its products.

Warranty: W/WH-Commercial Series

COMMERCIAL LIMITED EXPRESS WARRANTY

Unless a statement is specifically identified as a warranty, statements made by Maritime Geothermal Ltd. ("MG") or its representatives relating to MG's products, whether oral, written or contained in any sales literature, catalogue or agreement, are not express warranties and do not form a part of the basis of the bargain, but are merely MG's opinion or commendation of MG's products.

SET FORTH HERE IS THE ONLY EXPRESS WARRANTY THAT APPLIES TO MG'S PRODUCTS. MG MAKES NO WARRANTY AGAINST LATENT DEFECTS. MG MAKES NO WARRANTY OF MERCHANTABILITY OF THE GOODS OR OF THE FITNESS OF THE GOODS FOR ANY PARTICULAR PURPOSE.

LIMITED EXPRESS COMMERCIAL WARRANTY - PARTS

MG warrants its Commercial Class products, purchased and retained in the United States of America and Canada, to be free from defects in material and workmanship under normal use and maintenance as follows:

- (1) Heat pumps / chillers built or sold by MG for one (1) year from the Warranty Inception Date (as defined below).
- (2) Compressors of above units for five (5) years from the Warranty Inception Date (as defined below).
- (3) Other accessories, when purchased separately, for (1) year from the date of shipment from MG.

The "Warranty Inception Date" shall be the date of original unit installation, as per the date on the installation Startup Record; or sixty (60) days from date of unit shipment from MG, whichever comes first.

To make a claim under this warranty, parts must be returned to MG in Petitcodiac, New Brunswick, freight prepaid, no later than ninety (90) days after the date of the failure of the part. If MG determines the part to be defective and within MG's Limited Express Commercial Warranty, MG shall, when such part has been either replaced or repaired, return such to a factory recognized distributor, dealer or service organization, freight prepaid. The warranty on any part repaired or replaced under warranty expires at the end of the original warranty period.

LIMITED EXPRESS COMMERCIAL WARRANTY - LABOUR

MARITIME GEOTHERMAL LTD. will not be responsible for any consequential damages or labour costs incurred.

This warranty does not cover and does not apply to:

- (1) Air filters, fuses, refrigerant, fluids, oil.
- (2) Products relocated after initial installation.
- (3) Any portion or component of any system that is not supplied by MG, regardless of the cause of the failure of such portion or component.
- (4) Products on which the unit identification tags or labels have been removed or defaced.
- (5) Products on which payment to MG, or to the owner's seller or installing contractor, is in default.
- (6) Products subjected to improper or inadequate installation, including but not limited to:
 - Indoor or outdoor loop flow lower than listed in engineering specification or as expressly approved by MARITIME GEOTHERMAL LTD.
 - Operating the heat pump either manually or with automated controls so that the unit is forced to function outside its normal operating range
 - Disabling of safety controls
 - Insufficient loop antifreeze concentration for loop temperature, or antifreeze concentration incorrectly set in control board
 - Fouled heat exchangers due to poor water quality
 - Failure to use strainers or clean them regularly
 - Impact or physical damage sustained by the heat pump
 - Poor refrigeration maintenance practices, including brazing without nitrogen flow, or using wrong braze/flux
 - Incorrect voltage or missing phase supplied to unit
 - Unit modified electrically or mechanically from factory supplied condition
 - Water quality outside of recommended limits (e.g. salinity or pH)
 - Unit not mounted with supplied anti-vibration grommets when specified for use
 - Corrosion damage due to corrosive ambient environment
 - Failure due to excessive cycling caused by improper mechanical setup or improperly programmed external controller
 - Physical loads or pressures placed on unit from external equipment
- (7) Mold, fungus or bacteria damage
- (8) Corrosion or abrasion of the product.
- (9) Products supplied by others.
- (10) Electricity or fuel, or any increases or unrealized savings in same, for any reason whatsoever.

MG is not responsible for:

- (1) The costs of fluids, refrigerant or system components **supplied by others**, or associated **labour** to repair or replace the same, which is incurred as a result of a defective part covered by MG's Limited Commercial Warranty.
- (2) The costs of **labour**, refrigerant, materials, or service incurred in diagnosis and removal of defective part, or in obtaining and replacing the new or repaired part.
- (3) Transportation costs of the defective part from the installation site to MG, or of the return of that part if warranty coverage declined.
- (4) The costs of normal maintenance.

MG'S LIABILITY UNDER THE TERMS OF THIS LIMITED WARRANTY SHALL APPLY ONLY TO THE MG UNITS REGISTERED WITH MG THAT BEAR THE MODEL AND SERIAL NUMBERS STATED ON THE INSTALLATION START UP RECORD, AND MG SHALL NOT, IN ANY EVENT, BE LIABLE UNDER THE TERMS OF THIS LIMITED WARRANTY UNLESS THIS INSTALLATION START UP RECORD HAS BEEN ENDORSED BY OWNER & DEALER/INSTALLER AND RECEIVED BY MG LIMITED WITHIN 90 DAYS OF START UP.

Limitation: This Limited Express Commercial Warranty is given in lieu of all other warranties. If, notwithstanding the disclaimers contained herein, it is determined that other warranties exist, any such express warranty, including without limitation any express warranties or any implied warranties of fitness for particular purpose and merchantability, shall be limited to the duration of the Limited Express Commercial Warranty.

LIMITATION OF REMEDIES

In the event of a breach of the Limited Express Commercial Warranty, MG will only be obligated at MG's option to repair the failed part or unit, or to furnish a new or rebuilt part or unit in exchange for the part or unit which has failed. If after written notice to MG's factory in Petitcodiac, New Brunswick of each defect, malfunction or other failure, and a reasonable number of attempts by MG to correct the defect, malfunction or other failure, and the remedy fails of its essential purpose, MG shall refund the purchase price paid to MG in exchange for the return of the sold good(s). Said refund shall be the maximum liability of MG. **THIS REMEDY IS THE SOLE AND EXCLUSIVE REMEDY OF THE BUYER OR PURCHASER AGAINST MG FOR BREACH OF CONTRACT, FOR THE BREACH OF ANY WARRANTY OR FOR MG'S NEGLIGENCE OR IN STRICT LIABILITY.**

LIMITATION OF LIABILITY

MG shall have no liability for any damages if MG's performance is delayed for any reason or is prevented to any extent by any event such as, but not limited to: any war, civil unrest, government restrictions or restraints, strikes, or work stoppages, fire, flood, accident, shortages of transportation, fuel, material, or labour, acts of God or any other reason beyond the sole control of MG. **MG EXPRESSLY DISCLAIMS AND EXCLUDES ANY LIABILITY FOR CONSEQUENTIAL OR INCIDENTAL DAMAGE IN CONTRACT, FOR BREACH OF ANY EXPRESS OR IMPLIED WARRANTY, OR IN TORT, WHETHER FOR MG'S NEGLIGENCE OR AS STRICT LIABILITY.**

OBTAINING WARRANTY PERFORMANCE

Normally, the dealer or service organization who installed the products will provide warranty performance for the owner. Should the installer be unavailable, contact any MG recognized distributor, dealer or service organization. If assistance is required in obtaining warranty performance, write or call Maritime Geothermal Ltd.

NOTE: Some states or Canadian provinces do not allow limitations on how long an implied warranty lasts, or the limitation or exclusions of consequential or incidental damages, so the foregoing exclusions and limitations may not apply to you. This warranty gives you specific legal rights, and you may also have other rights which vary from state to state and from Canadian province to Canadian province.