

# Engineering Specification

## W-55-HACW-X-\*T-\*\* Liquid to Water Geothermal Heat Pump R454b, 60 Hz



**Maritime Geothermal Ltd.**  
P.O. Box 2555, 170 Plantation Road  
Petitcodiac, NB E4Z 6H4  
(506) 756-8135

info@nordicghp.com  
www.nordicghp.com  
002899SPC-01

# Model Nomenclature

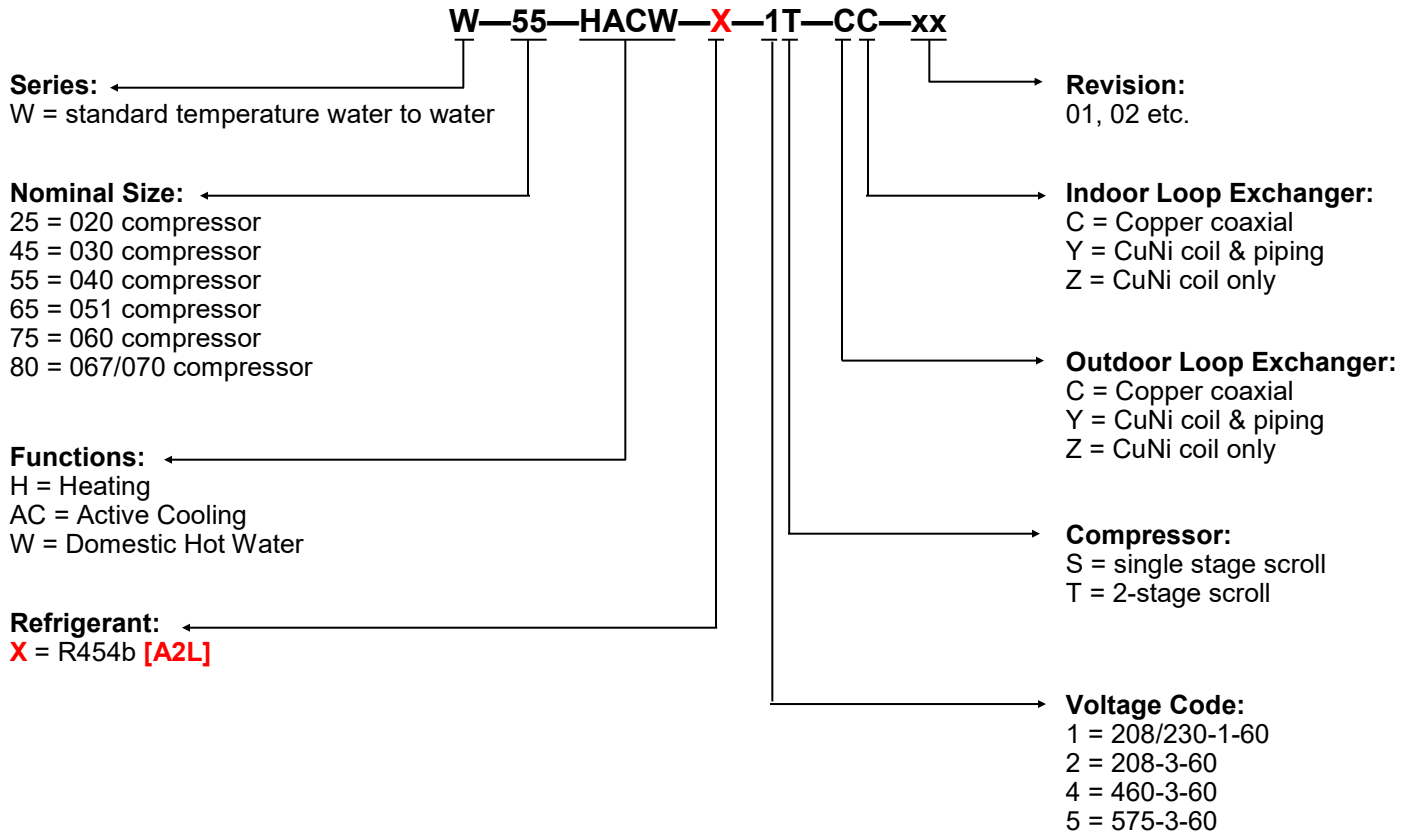

APPLICATION TABLE										
MODEL	FUNCTION	REFRIGERANT	VOLTAGE	COMPRESSOR	OUTDOOR HEAT EXCHANGER	INDOOR HEAT EXCHANGER	REVISIONS			
W-55	HACW	X	1 2 4 5	T	C Y Z	C Y Z	01			

This manual applies only to the models and revisions listed in this table.

Maritime Geothermal Ltd. has a continuous improvement policy and reserves the right to modify specification data at any time without prior notice .

# Design Features

---

- R454b refrigerant (GWP=466) is climate change-friendly. Note that R454b has an **A2L** classification.
- AHRI certified & Energy Star listed for performance
- TUV certified for safety (CSA/UL/ETL equivalent)
- Satin galvanized steel cabinet with powder coat finish, acoustically insulated (1/2" & 1" thick)
- All connections located on same side
- Access panels on all four sides, serviceable from two; swing out electrical box for compressor access
- Refrigeration service ports located inside unit (1/4" Schrader)
- Insulated coaxial heat exchanger and piping, available in copper or cupro-nickel (CuNi)
- 1" brass FPT fittings for loop connections
- Connection points for outdoor and indoor circulator pump power
- Two-stage scroll compressor, with start capacitor kit on single phase models
- Dual-grommet-mounted compressor for reduced noise and vibration
- Suction line accumulator
- Liquid line filter-dryer & sight glass
- 4-way reversing valve
- Electronic Expansion Valve (EEV)
- Refrigerant high and low pressure sensors
- Suction line temperature sensor
- Manual reset high pressure control
- Compressor current sensor as standard equipment
- Refrigerant leak detector as standard equipment
- Temperature sensors on all 4 water lines
- Control transformer with resettable breaker or fuse protection
- Advanced control board with BACNet interface for remote operation and data access including all sensor data and alarm conditions, PWM outputs (or 0-10VDC), configurable analog inputs (0-5VDC or 4-20mA) with onboard 5VDC, 12VDC and 24VDC power supplies
- USB port for complete data access including real-time charting, data logging, and diagnostic functionality with manual override operation
- 2 x 16 LCD display for control and data access
- Onboard water temperature control, with outdoor reset (requires outdoor temperature sensor accessory)
- Random start on power up (0-2 minutes)
- 24VAC and 0-10VDC output for external pump / water valve control (24VAC 500mA max)
- Double wall Domestic Hot Water (DHW) desuperheater suitable for heating potable water
- SS circulator for domestic hot water (desuperheater) circuit, 1/2" brass FPT connections

# Available Accessories

---

- Hydronic buffer tank with 12, 15, or 20kW of electric backup elements
- Circulator pump module with loop / unit isolation valves (230VAC) for ground loop applications
- Barbed P/T port adapters for heat pump
- Anti-vibration pad for under unit
- Compressor sound jacket
- Secure Start module
- 1" water valve (motorized, solenoid, or modulating) & wiring harness for open loop applications
- Outdoor temperature sensor with enclosure, for outdoor reset functionality
- Compressor current sensor

# Design Features

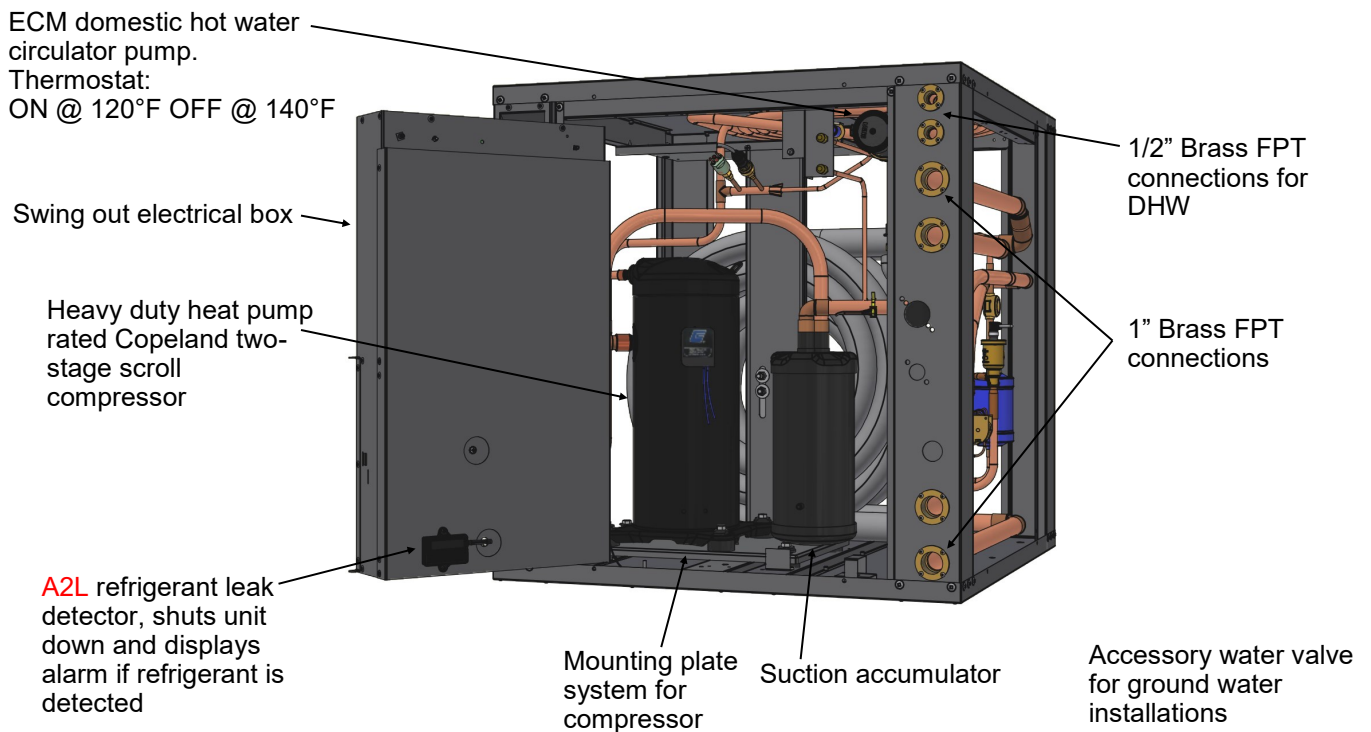
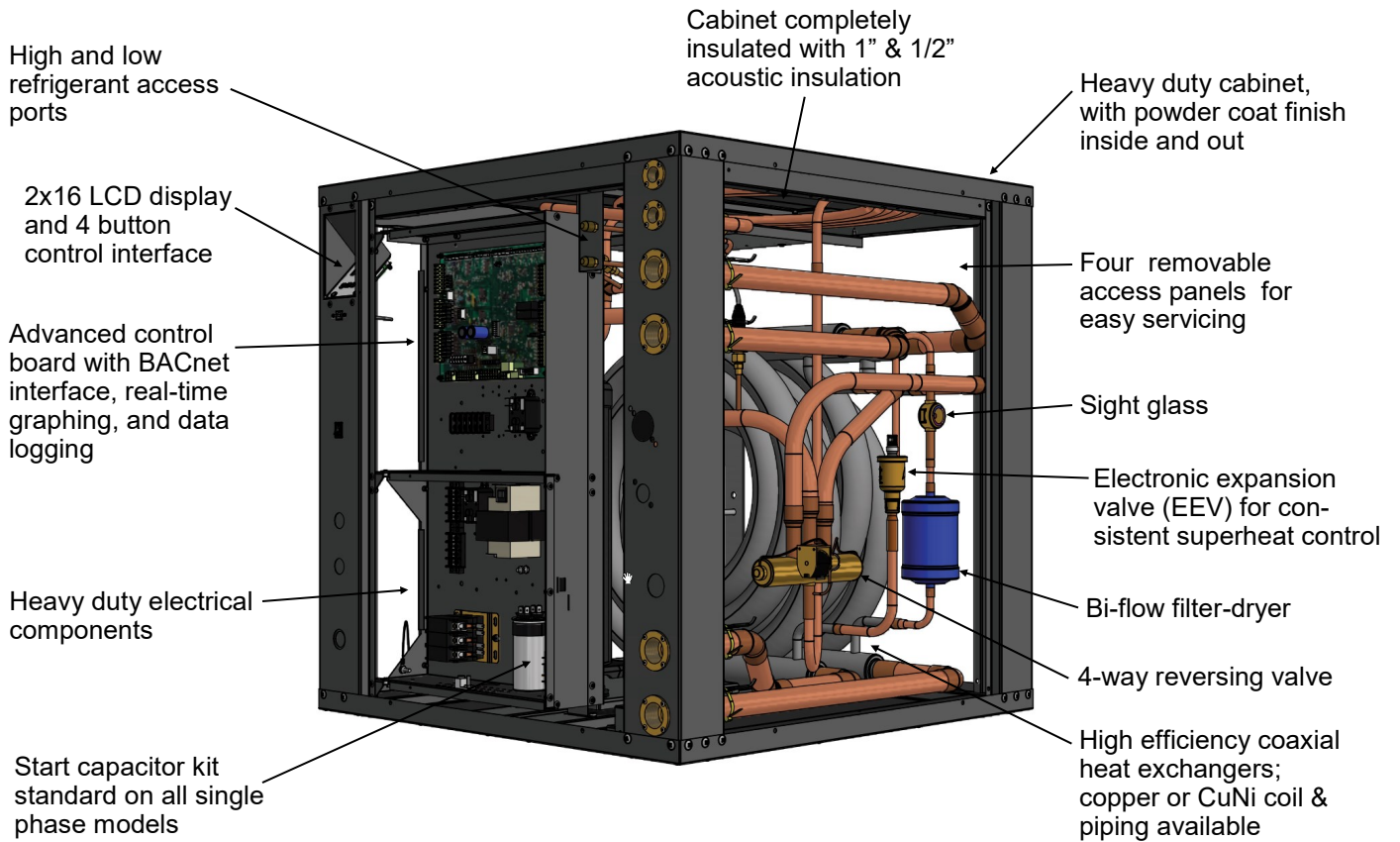

# Dimensions

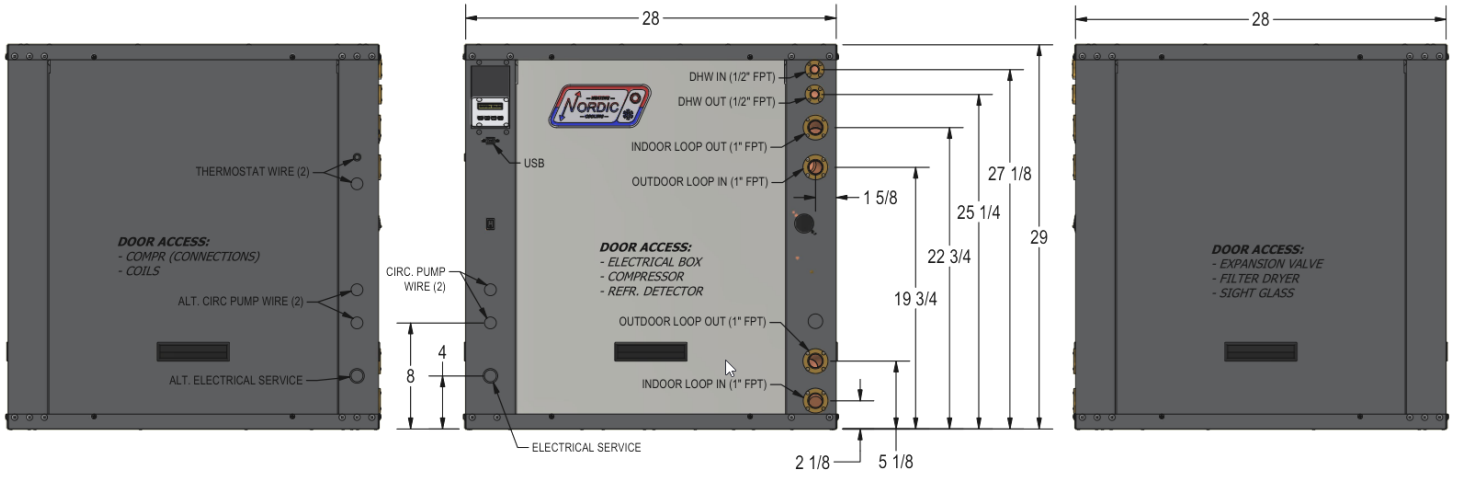

LEFT SIDE  
CLEARANCE  
OPTIONAL

RECOMMENDED  
FRONT CLEARANCE:  
**2 FT**

RECOMMENDED  
RIGHT SIDE CLEARANCE:  
**2 FT**

NO BACK CLEARANCE REQUIRED

# Specifications

Electrical Specifications (R454b)										
Nomenclature Identifier	Power Supply			Compressor		Circulators	FLA	MCA	Max. Breaker	Minimum Wire Size
	V-ø-Hz	MIN	MAX	RLA	LRA	Max. A	Amps	Amps	Amps	ga
1	208/230-1-60	187	253	18.3	138	7.0	26.1	30.7	50	#8-2*
2	208-3-60	187	229	11.9	112	7.0	19.7	22.7	40	#8-3*
4	460-3-60	414	506	6.8	62	-	7.6	9.3	15	#14-3
5	575-3-60	518	632	4.8	39	-	5.6	6.8	15	#14-3

\* additional conductor required if connecting 115VAC circulators to the unit

Shipping Information				
MODEL	WEIGHT lb. (kg)	DIMENSIONS in (cm)		
		L	W	H
W-55	390 (177)	34 (86)	34 (86)	35 (89)

Sound Levels (dBA)*		
MODEL	1 ft distance	3 ft distance
W-55	56.4	54.9

\* With all doors installed.

Refrigerant Charge				
MODEL	lb	kg	Refrigerant	Oil Type
W-55	7.0	3.2	R410a	POE

- Oil capacity is marked on the compressor label.  
 - Refrigerant charge is subject to revision; actual charge is indicated on the unit nameplate.

Required Indoor & Outdoor Loop Flow Rate		
MODEL	gpm	L/s
W-55	12	0.76

Note for circ pump sizing: flow rate may be greater than required for boiler of a similar heating capacity.

	Loop Pressure Drop Data		INDOOR (water 104°F)		OUTDOOR (water 50°F)		OUTDOOR (15% methanol 32°F)		OUTDOOR (35% prop. glycol 32°F)		
	gpm	L/s	psi	kPa	psi	kPa	psi	kPa	psi	kPa	
	W-55	6	0.38	1.1	7.6	1.2	8.3	1.3	9.0	1.7	12
7		0.44	1.5	10	1.6	11	1.6	11	2.1	14	
8		0.50	1.8	12	1.9	13	2.1	14	2.8	19	
9		0.57	2.2	15	2.4	17	2.4	17	3.2	22	
10		0.63	2.7	19	2.9	20	3.1	21	4.1	28	
11		0.69	2.8	19	19	3.1	21	3.6	25	4.7	33
12		0.76	3.4	23	3.7	26	4.4	30	5.8	40	
13		0.82	4	28	4.3	30	5	34	6.6	45	
14		0.88	4.7	32	5	34	5.7	39	7.5	52	
15	0.95	5.6	39	5.8	40	6.4	44	8.4	58		

Operating Temperature Limits					
Loop	Mode	Parameter	(°F)	(°C)	Note
Indoor	Heating	Minimum ELT	50	10	Reduce flow if necessary during startup.
	Heating	Maximum LLT	120	49	
	Cooling	Minimum LLT	41	5	Water system (no antifreeze).
	Cooling	Minimum LLT	32	0	Antifreeze system. Adequate freeze protection required.
	Cooling	Maximum ELT	80	27	
Outdoor	Heating	Minimum ELT	39	4	Ground water (open loop) system.
	Heating	Minimum ELT	23	-5	Ground loop system. Adequate freeze protection required.
	Cooling	Minimum ELT	39	4	Ground water (open loop) system.
	Cooling	Minimum ELT	32	0	Ground loop system. Adequate freeze protection required.
	Cooling	Maximum LLT	120	49	

\* Values in this table are for rated liquid flow values.

# BACnet Interface

The BACnet interface is an **MS/TP** connection via RS-485 twisted pair. BACnet **IP** is not available. Recommended wire: 22-24 AWG single twisted pair, 100-120 Ohms impedance, 17pF/ft or lower capacitance, with braided or aluminum foil shield, such as Belden 9841 or 89841.

The connector on the control board is a three wire removable screw connector. The signals are as follows:

- A: Communications line (+) (right pin)
- B: Communications line (-) (middle pin)
- C: Ground connection (left pin)

If connecting multiple units to one RS-485 connection point, connect the signal cable from the master building controller to the first unit. Connect the second unit to the first unit (in same connector), connect the third unit to the second unit, and so on until all units are connected (daisy-chain). Remove the TERM jumper (located just above the BACnet connector on control board) from all units except the last one. The shield ground should be connected only to the GND pin of the unit for single unit installations. For multiple units, the shield ground should only be connected to the GND pin of the last unit. The shield grounds for intermediate units should be connected together. The shield ground should be left unconnected at the building controller end for all cases.

Vendor: Maritime Geothermal Ltd.  
Vendor ID: 260  
Model Name: MGT GEN2 Control Board

The following parameters can be set via the PC App's *Configuration Window*:

- 1) **Baud rate**  
9600, 19200, 38400, or 76800
- 2) **MAC address**  
Maximum value is 125.
- 3) **Instance number**  
Maximum value is 4194303.

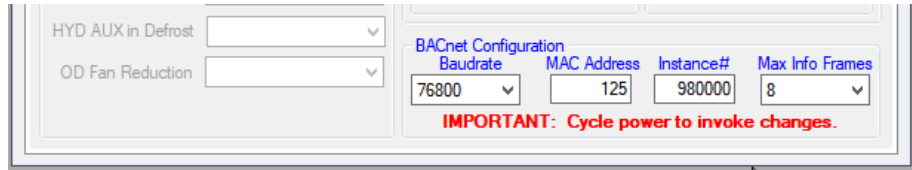

The BACnet parameter **Max\_Master** has a fixed value of **127** in this device.

BACnet data is available regardless of the selected control method. In order to control the unit via the BACnet interface, set **Control Source** to **BACnet** either by using the PC App's configuration window or the LCD menus.

**Refer to *Application, Installation, & Service Manual* for BACnet objects (read and write).**

# Standard Capacity Ratings

Standards C13256-2 / ISO13256-2 / ARI 13256-2

Standard Capacity Ratings - <b>Ground Loop Heating*</b>						60Hz	
EWT 104°F (40°C)				*15% Methanol by Weight Ground Loop Fluid			
				STAGE 1 - ELT 41°F (5°C) STAGE 2 - ELT 32°F (0°C)			
Model	Liquid Flow (Outdoor & Indoor)		Mode	Input Energy	Capacity		COP <sub>H</sub>
	gpm	L/s			Btu/hr	kW	
W-55	12.0	0.76	Stage 1	2,498	26,000	7.6	3.05
			Stage 2	3,140	32,700	9.6	3.05

Standard Capacity Ratings - <b>Ground Loop Cooling*</b>						60Hz		
EWT 53.6°F (12°C)				*15% Methanol by Weight Ground Loop Fluid				
				STAGE 1 - ELT 68°F (20°C) STAGE 2 - ELT 77°F (25°C)				
Model	Liquid Flow (Outdoor & Indoor)		Mode	Input Energy	Capacity		COP <sub>c</sub>	EER
	gpm	L/s			Btu/hr	kW		
W-55	12.0	0.76	Stage 1	1,562	30,300	8.9	5.69	19.4
			Stage 2	2,604	38,800	11.4	4.37	14.9

Standard Capacity Ratings - <b>Ground Water Heating</b>						60Hz	
EWT 104°F (40°C)				ELT 50°F (10°C)			
Model	Liquid Flow (Outdoor & Indoor)		Mode	Input Energy	Capacity		COP <sub>H</sub>
	gpm	L/s			Btu/hr	kW	
W-55	12.0	0.76	Stage 1	2,393	31,700	9.3	3.88
			Stage 2	3,441	44,400	13.0	3.78

Standard Capacity Ratings - <b>Ground Water Cooling</b>						60Hz		
EWT 53.6°F (12°C)				ELT 59°F (15°C)				
Model	Liquid Flow (Outdoor & Indoor)		Mode	Input Energy	Capacity		COP <sub>c</sub>	EER
	gpm	L/s			Btu/hr	kW		
W-55	12.0	0.76	Stage 1	1,299	32,200	9.4	7.27	24.8
			Stage 2	2,058	42,400	12.4	6.04	20.6



# Performance Tables (US UNITS)

W-55-HACW-X-1T R454b, 60 Hz, YAS40K1E-PFV

	OUTDOOR LOOP (15% Methanol)						ELECTRICAL		INDOOR LOOP (Water)						
	ELT (°F)	Evap. Temp.	Flow (gpm)	LLT (°F)	Delta T (°F)	Heat Abs. (Btu/hr)	Compressor Current (A)*	Input Power (W)	EWT (°F)	Cond. Temp.	Flow (gpm)	LWT (°F)	Delta T (°F)	Heating (Btu/hr)	COP <sub>H</sub>
<b>HEATING</b>	25	14	12	22	-3.2	18,900	12.9	3,007	104	115	12	109	4.8	28,900	2.82
	30	19	12	26	-3.6	21,200	13.2	3,102		116	12	109	5.3	31,500	2.98
	35	24	12	31	-4.1	23,800	13.6	3,189		116	12	110	5.7	34,400	3.16
	40	29	12	36	-4.5	26,600	14.0	3,277		117	12	110	6.3	37,500	3.35
	45	33	12	40	-5.1	29,700	14.4	3,358		117	12	111	6.8	40,900	3.57
	50	38	12	44	-5.6	32,900	14.8	3,444		118	12	111	7.4	44,400	3.78
	55	43	12	49	-6.2	36,300	15.3	3,530		119	12	112	8.0	48,100	3.99
	60	47	12	53	-6.9	40,000	15.7	3,611		119	12	113	8.7	52,100	4.23
	65	52	12	57	-7.6	44,000	16.1	3,700		120	12	113	9.4	56,400	4.47
	70	57	12	62	-8.3	48,200	16.6	3,789		120	12	114	10.2	60,900	4.71
	25	15	12	22	-2.9	17,200	14.6	3,383	115	125	12	120	4.8	28,500	2.47
	30	20	12	27	-3.3	19,400	14.9	3,455	115	125	12		5.2	30,900	2.62
	35	25	12	31	-3.7	21,900	15.1	3,526	114	125	12		5.6	33,700	2.80
	40	29	12	36	-4.2	24,600	15.3	3,587	114	125	12		6.1	36,600	2.99
	45	34	12	40	-4.7	27,500	15.6	3,650	113	126	12		6.7	39,700	3.19
	50	39	12	45	-5.2	30,700	15.9	3,705	113	126	12		7.2	43,100	3.41
	55	43	12	49	-5.8	34,100	16.1	3,758	112	126	12		7.8	46,700	3.64
	60	48	12	54	-6.5	37,800	16.4	3,816	112	126	12		8.5	50,600	3.89
	65	53	12	58	-7.2	41,700	16.7	3,868	111	126	12		9.2	54,700	4.14
	70	57	12	62	-7.9	45,900	17.1	3,930	110	126	12		9.9	59,100	4.41
<b>COOLING</b>	50	72	12	59	8.6	50,200	4.1	1,874	54	38	12	46	-7.3	43,900	23.4
	55	77	12	64	8.5	49,600	4.4	1,969		38	12	46	-7.2	43,000	21.8
	60	82	12	68	8.4	49,100	4.7	2,083		39	12	47	-7.0	42,100	20.2
	65	87	12	73	8.3	48,500	5.0	2,213		39	12	47	-6.9	41,100	18.6
	70	91	12	78	8.3	48,100	5.3	2,363		40	12	47	-6.7	40,200	17.0
	75	96	12	83	8.2	47,700	5.7	2,532		40	12	47	-6.6	39,200	15.5
	80	101	12	88	8.2	47,300	6.0	2,720		41	12	47	-6.4	38,200	14.0
	85	106	12	93	8.1	46,900	6.4	2,922		41	12	47	-6.2	37,100	12.7
	90	110	12	98	8.1	46,700	6.8	3,146		42	12	48	-6.1	36,100	11.5
	95	115	12	103	8.0	46,400	7.3	3,388		42	12	48	-5.9	35,000	10.3

# Performance Tables (METRIC UNITS)

**W-55-HACW-X-1T** R454b, 60 Hz, YAS40K1E-PFV

METRIC

OUTDOOR LOOP (15% Methanol)						ELECTRICAL		INDOOR LOOP (Water)						
ELT (°C)	Evap. Temp.	Flow (L/s)	LLT (°C)	Delta T (°C)	Heat Abs. (kW)	Compressor Current (A)	Input Power (W)	EWT (°C)	Cond. Temp.	Flow (L/s)	LWT (°C)	Delta T (°C)	Heating (kW)	COP <sub>H</sub>
-3.9	-9.8	0.8	-5.7	-1.8	5.5	12.9	3,007	40	46.2	0.8	42.7	2.7	8.5	2.82
-1.1	-7.2	0.8	-3.1	-2.0	6.2	13.2	3,102		46.6	0.8	42.9	2.9	9.2	2.98
1.7	-4.6	0.8	-0.6	-2.3	7.0	13.6	3,189		46.8	0.8	43.2	3.2	10.1	3.16
4.4	-1.9	0.8	1.9	-2.5	7.8	14.0	3,277		47.2	0.8	43.5	3.5	11.0	3.35
7.2	0.7	0.8	4.4	-2.8	8.7	14.4	3,358		47.4	0.8	43.8	3.8	12.0	3.57
10.0	3.3	0.8	6.9	-3.1	9.6	14.8	3,444		47.8	0.8	44.1	4.1	13.0	3.78
12.8	5.9	0.8	9.4	-3.4	10.6	15.3	3,530		48.1	0.8	44.4	4.4	14.1	3.99
15.6	8.6	0.8	11.8	-3.8	11.7	15.7	3,611		48.4	0.8	44.8	4.8	15.3	4.23
18.3	11.2	0.8	14.1	-4.2	12.9	16.1	3,700		48.7	0.8	45.2	5.2	16.5	4.47
21.1	13.8	0.8	16.5	-4.6	14.1	16.6	3,789		49.0	0.8	45.7	5.7	17.8	4.71
-3.9	-9.3	0.8	-5.5	-1.6	5.0	14.6	3,383	46.2	51.7	0.8	49	2.7	8.4	2.47
-1.1	-6.7	0.8	-2.9	-1.8	5.7	14.9	3,455	46.0	51.7	0.8		2.9	9.1	2.62
1.7	-4.1	0.8	-0.4	-2.1	6.4	15.1	3,526	45.8	51.8	0.8		3.1	9.9	2.80
4.4	-1.5	0.8	2.1	-2.3	7.2	15.3	3,587	45.5	51.9	0.8		3.4	10.7	2.99
7.2	1.1	0.8	4.6	-2.6	8.1	15.6	3,650	45.2	52.0	0.8		3.7	11.6	3.19
10.0	3.7	0.8	7.1	-2.9	9.0	15.9	3,705	44.9	52.1	0.8		4.0	12.6	3.41
12.8	6.3	0.8	9.6	-3.2	10.0	16.1	3,758	44.6	52.1	0.8		4.3	13.7	3.64
15.6	8.8	0.8	12.0	-3.6	11.1	16.4	3,816	44.2	52.2	0.8		4.7	14.8	3.89
18.3	11.4	0.8	14.3	-4.0	12.2	16.7	3,868	43.8	52.3	0.8		5.1	16.0	4.14
21.1	14.1	0.8	16.7	-4.4	13.5	17.1	3,930	43.4	52.4	0.8		5.5	17.3	4.41
ELT (°C)	Cond. Temp.	Flow (L/s)	LLT (°C)	Delta T (°C)	Heat Rej. (kW)	Compressor Current (A)	Input Power (W)	EWT (°C)	Evap. Temp.	Flow (L/s)	LWT (°C)	Delta T (°C)	Cooling (kW)	COP <sub>C</sub>
10.0	22	0.8	14.8	4.8	14.70	4.1	1,874	12	3	0.8	7.9	-4.1	12.9	6.86
12.8	25	0.8	17.5	4.7	14.50	4.4	1,969		3	0.8	8.0	-4.0	12.6	6.39
15.6	28	0.8	20.3	4.7	14.40	4.7	2,083		4	0.8	8.1	-3.9	12.3	5.92
18.3	30	0.8	22.9	4.6	14.20	5.0	2,213		4	0.8	8.2	-3.8	12.0	5.45
21.1	33	0.8	25.7	4.6	14.10	5.3	2,363		4	0.8	8.3	-3.7	11.8	4.98
23.9	36	0.8	28.5	4.6	14.00	5.7	2,532		5	0.8	8.3	-3.7	11.5	4.54
26.7	38	0.8	31.3	4.6	13.90	6.0	2,720		5	0.8	8.4	-3.6	11.2	4.10
29.4	41	0.8	33.9	4.5	13.70	6.4	2,922		5	0.8	8.6	-3.4	10.9	3.72
32.2	44	0.8	36.7	4.5	13.70	6.8	3,146		5	0.8	8.6	-3.4	10.6	3.37
35.0	46	0.8	39.4	4.4	13.60	7.3	3,388		6	0.8	8.7	-3.3	10.3	3.02

# WWH-Series (GEN2) Schematic Diagram 208/230-1-60

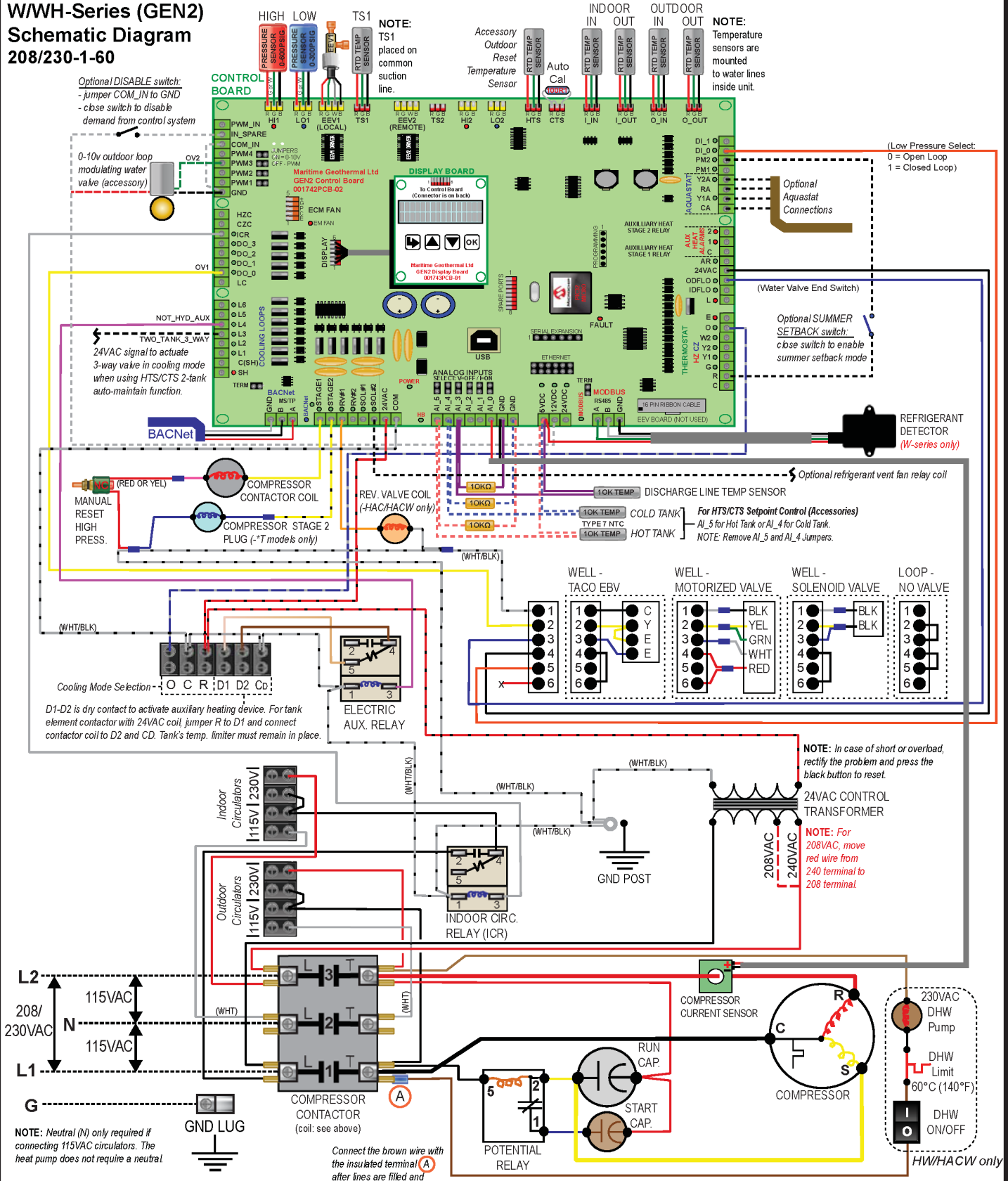

01	Initial Release	D. RHEAULT	D. RHEAULT	18-Oct-2024	<b>Maritime Geothermal Ltd.</b> P.O. Box 2555 170 Plantation Rd. Petitediac, NB CANADA E4Z 6H4	Drawing Name <b>WWH-**-H***-X/Y-1*.-** Schematic Diagram</b>		
REV	ECO#	IMPL BY	APVD BY	DATE			Size LET	Drawing Number 002799SCH

# WWH-Series (GEN2) Schematic Diagram 208-3-60

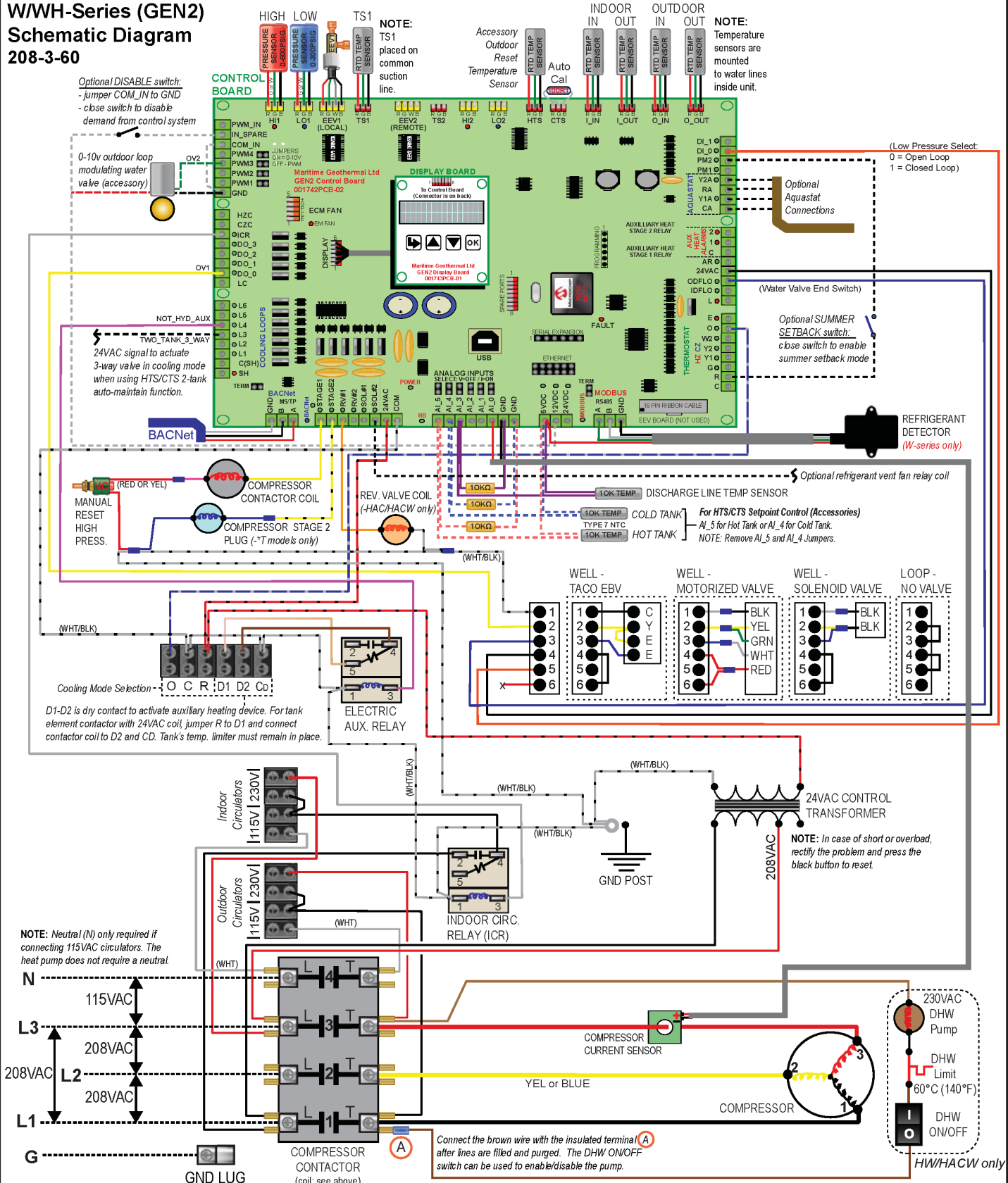

01	Initial Release	D. RHEAULT	D. RHEAULT	18-Oct-2024	<b>MARITIME GEOTHERMAL LTD.</b> P.O. Box 2555 170 Plantation Rd. Pettrcodiac, NB CANADA E4Z 6H4	Drawing Name <b>WWH-**-H***-X/Y-2*.-** Schematic Diagram</b>	Size LET	Drawing Number 002800SCH	Drawing Rev 01	Sheet 1 / 1
REV	ECO#	IMPL BY	APVD BY	DATE						
Drawn By <b>D. RHEAULT</b>					Date 18-Oct-2024					
Checked By <b>D. RHEAULT</b>					Date 18-Oct-2024					
Eng. Approved By _____					Date _____					
Mfg. Approved By _____					Date _____					
Approved By _____					Date _____					

# WWH-Series (GEN2) Schematic Diagram 460-3-60

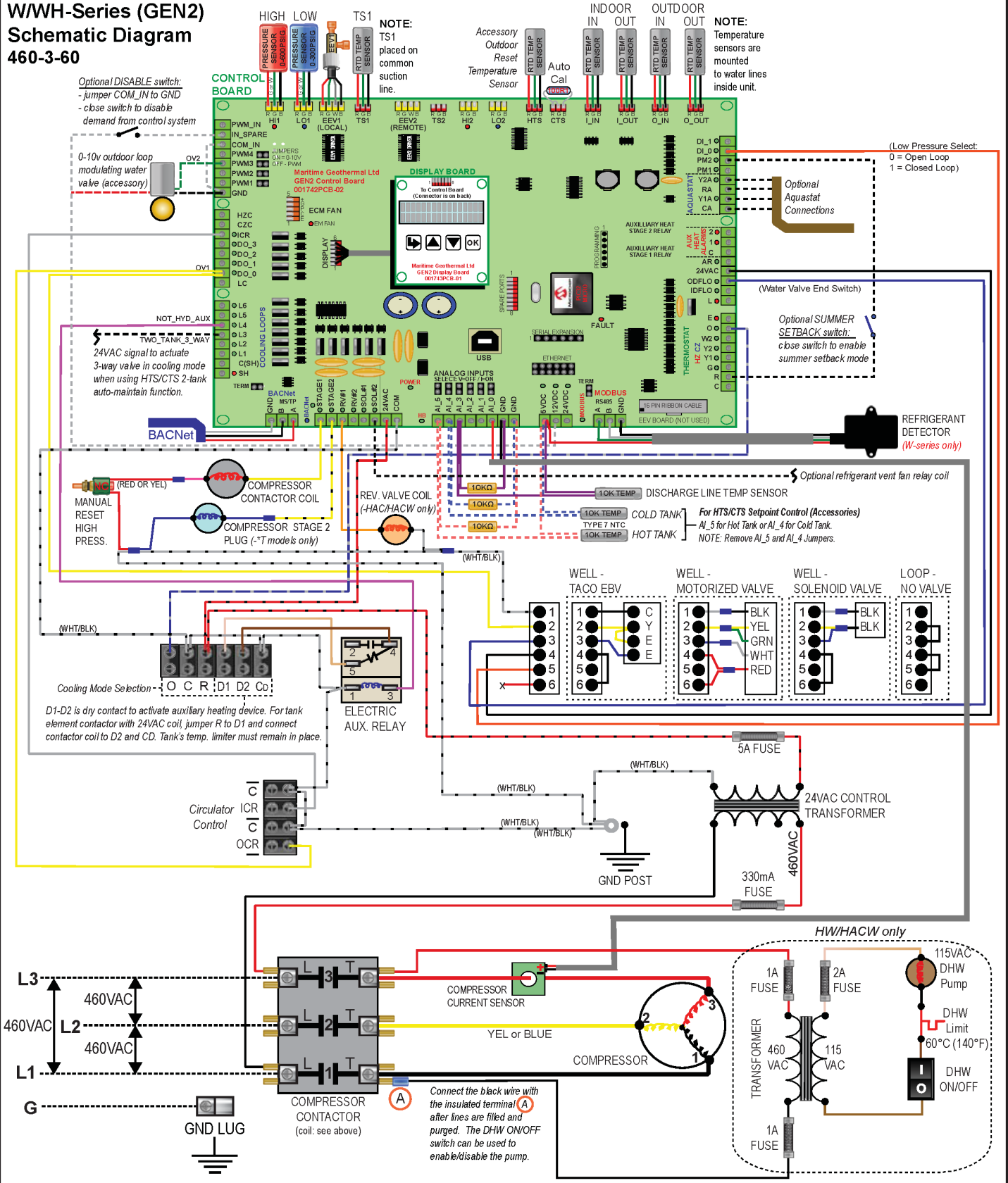

Drawn By <b>D. RHEAULT</b>	Date <b>18-Oct-2024</b>	<b>MARITIME GEOTHERMAL LTD.</b>	P.O. Box 2555 170 Plantation Rd. Petitcodiac, NB CANADA E4Z 6H4
Checked By <b>D. RHEAULT</b>	Date <b>18-Oct-2024</b>		
Eng. Approved By	Date	Drawing Name	
Mfg. Approved By	Date	WWH-**-H***-X/Y-4*.-** Schematic Diagram	
Approved By	Date	Size <b>LET</b>	Drawing Number <b>002801SCH</b>
		Drawing Rev <b>01</b>	Sheet <b>1 / 1</b>

# WWH-Series (GEN2) Schematic Diagram 575-3-60

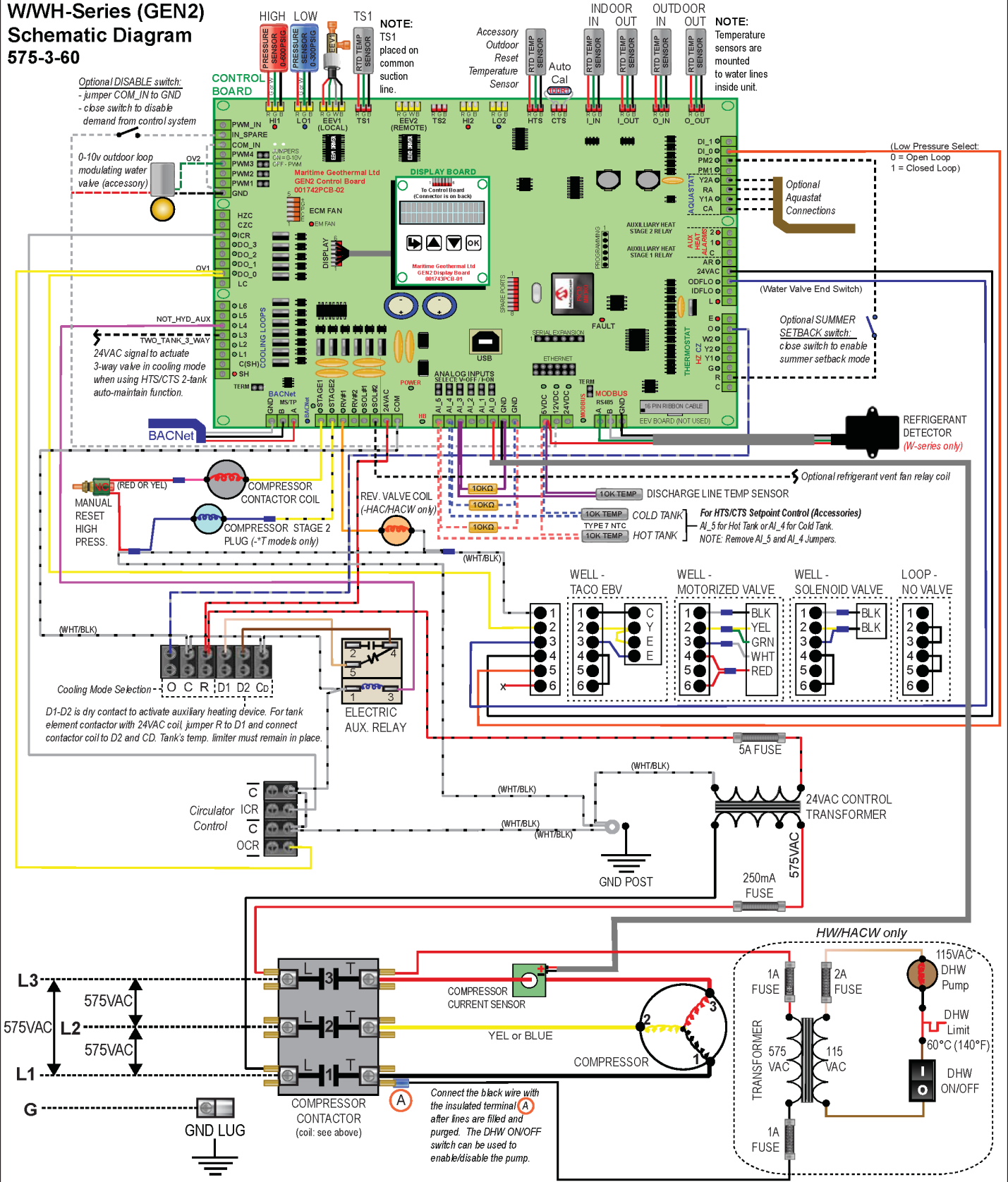

Drawn By <b>D. RHEAULT</b>	Date <b>18-Oct-2024</b>
Checked By <b>D. RHEAULT</b>	Date <b>18-Oct-2024</b>
Eng. Approved By	Date
Mfg. Approved By	Date
Approved By	Date

<b>MARITIME GEOTHERMAL LTD.</b>		P.O. Box 2555 170 Plantation Rd. Petitcodiac, NB CANADA E4Z 6H4	
Drawing Name			
WWH-**-H***-X/Y-5*.-** Schematic Diagram			
Size	Drawing Number	Drawing Rev	Sheet
LET	002802SCH	01	1 / 1

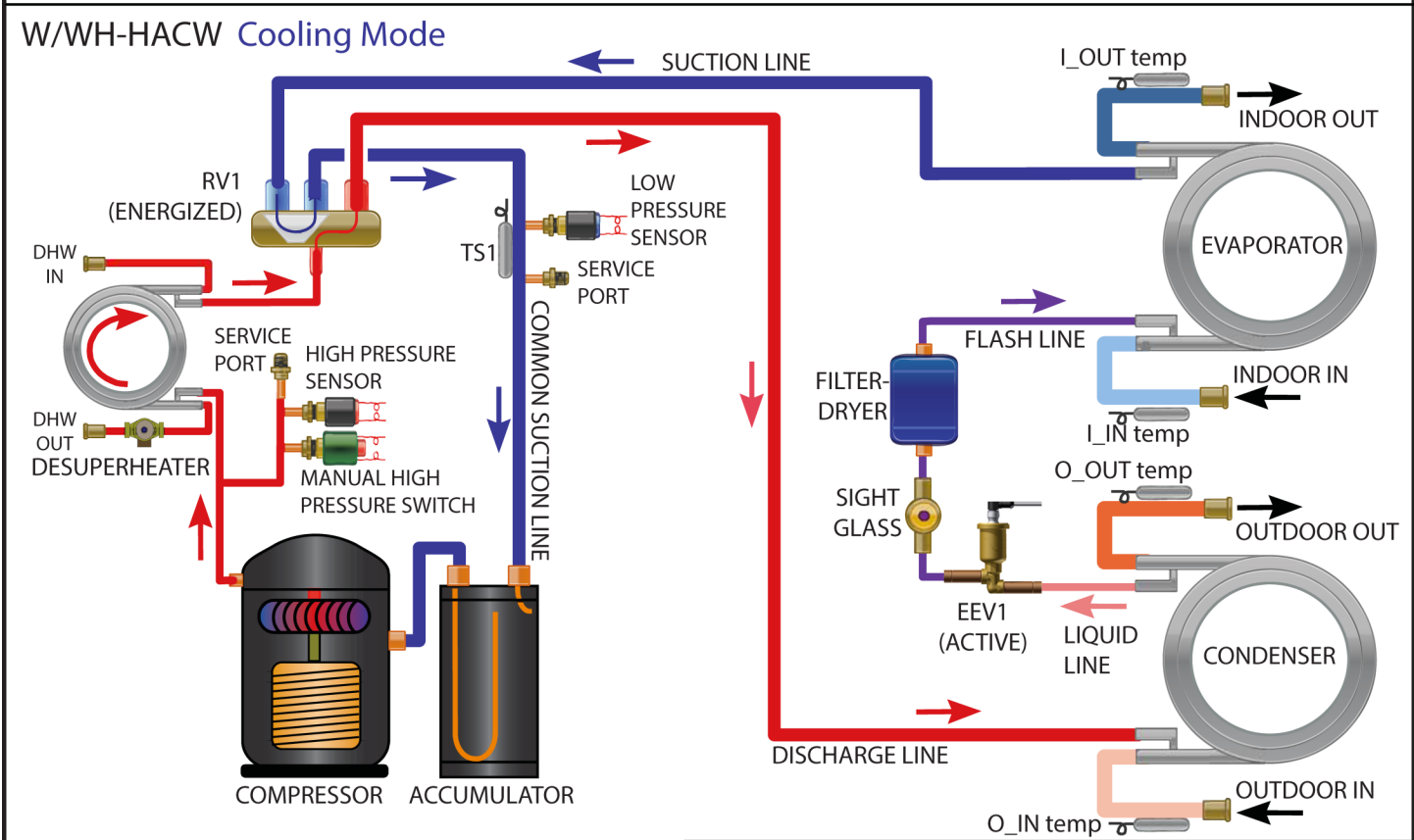
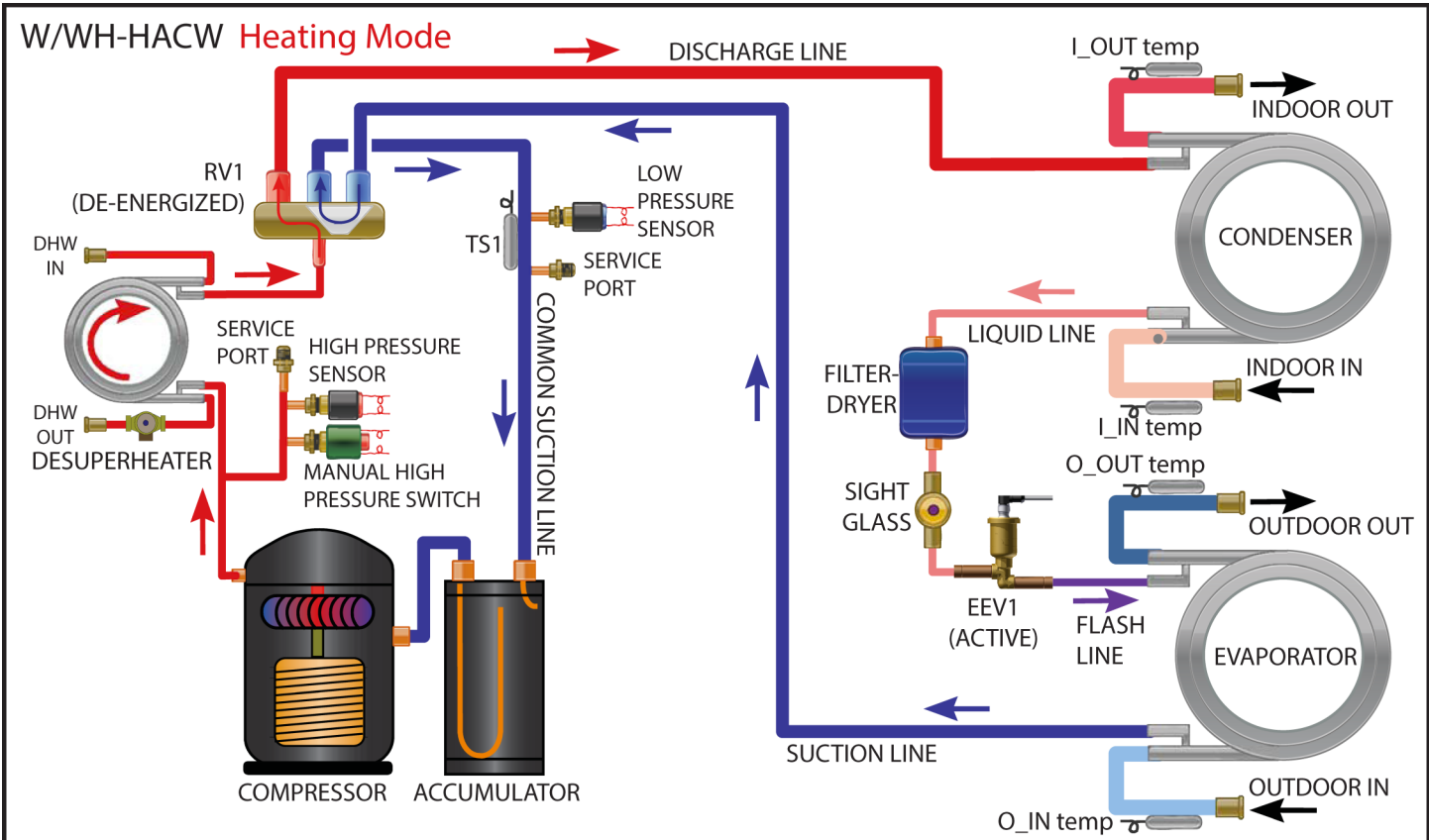

01	Initial Release	D. RHEAULT	D. RHEAULT	17-JUN-2019	Drawn By <b>Dan Rheault</b>	Date 17-JUN-2019	<b>MARITIME GEOTHERMAL LTD.</b> P.O. Box 2555 170 Plantation Rd. Petitcodiac, NB CANADA E4Z 6H4
REV	ECO#	IMPL BY	APVD BY	DATE	Checked By <b>Dan Rheault</b>	Date 17-JUN-2019	
					Eng. Approved By <b>Dan Rheault</b>	Date 17-JUN-2019	
					Mfg. Approved By	Date	
					Approved By	Date	Drawing Name <b>W/WH-HACW Series Refrigeration Circuit (GEN2, Reversing, with Desuperheater)</b>
					Size <b>LET</b>	Drawing Number <b>002398RCD</b>	Drawing Revision <b>01</b> Sheet <b>1 / 1</b>

# Engineering Guide Specifications

---

## General

The liquid source reversing water-to-water heat pump shall be a single packaged reverse-cycle heating/cooling unit, with desuperheating circuit for domestic hot water heating. The unit shall be listed by a nationally recognized safety-testing laboratory (NRTL), such as TUV, ETL, UL, or CSA. The unit shall be rated in accordance with applicable standards of the Air Conditioning, Heating, and Refrigeration Institute / International Standards Organization (AHRI/ISO) and/or Canadian Standards Association (CSA). The liquid source water to water heat pump unit, as manufactured by Maritime Geothermal, Petitcodiac, New Brunswick, shall be designed to operate correctly within liquid temperature ranges specified on the "Minimum and Maximum Operating Temperatures" page of this engineering specification document.

## Factory Quality

Each unit shall be run tested at the factory with water circulating through the indoor and outdoor loops. Quality control system checks shall include: computerized nitrogen pressurized leak test, evacuation of refrigeration circuit to sustained vacuum, accurate system charge, detailed heating and cooling mode tests, and quality cross check all operational and test conditions to pass/fail criteria. Units tested without water flow are not acceptable. The units shall be warranted by the manufacturer against defects in materials and workmanship in accordance with the warranty section at the end of this document. Optional extended factory warranty coverage may be available.

## Cabinet

Each unit shall be enclosed in a sheet metal cabinet. Cabinet shall be constructed of powder coated galvanized sheet metal of minimum 20 gauge. Sheet metal gauge shall be higher where structurally required. Design and construction of cabinet shall be such that it is rigid and passes the CSA/UL Loading Test requirements (200 lb roof test and 25 lb guard test). All panels shall be lined with minimum 1/2 inch [12.7 mm] thick acoustic type glass fiber insulation. All insulation shall meet the fire retardant provisions of NFPA 90A. This material shall also provide acoustical benefit. The unit must have a minimum of three access panels for serviceability of the compressor compartment. Units having only one access panel to compressor/heat exchangers/expansion device/refrigerant piping shall not be acceptable. The electrical box shall have separate holes and knockouts for entrance of line voltage and low voltage control wiring. All factory-installed wiring passing through factory knockouts and openings shall be protected from sheet metal edges at openings by plastic grommets.

## Refrigerant Circuit

All units shall contain only one sealed refrigerant circuit, containing a hermetic motor scroll compressor, Electronic Expansion Valve (EEV), coaxial heat exchangers, factory installed high and low pressure sensors, manual reset high pressure switch, service ports, liquid line filter-drier, sight glass, and suction accumulator.

Refrigerant used shall have a global warming potential (GWP) of less than 500. A refrigerant leak detector shall be factory installed.

Compressors shall be specified for heat pump duty with internal isolation consisting of rubber vibration isolators and mounting plate with rubber vibration isolators. Compressor motors shall have internal high temperature overload protection.

The water to refrigerant heat exchangers shall consist of a steel outer jacket with twisted copper inner tube, designed and certified for 600 psig [4136 kPa] working pressure on the refrigerant side and 450 psig [3108 kPa] on the water side. Heat exchangers headered together in parallel shall use a reverse-return or symmetrical arrangement on the water side and symmetrical arrangement on the refrigerant side to ensure even flow splitting. Heat exchangers shall be insulated over all of their outside surface with minimum 3/8" thick closed cell insulation. Insulation consisting of 1/8" closed-cell insulating tape shall not be acceptable. Cupro-nickel (CuNi) inner tube shall be available as a factory option.

The electronic expansion valve shall be of stepper-motor rather than pulsing type, and shall provide proper superheat control over the unit's operating range with minimal deviation from superheat setpoint. Superheat shall be determined through the suction pressure-temperature method. Externally mounted pressure controlled water regulating flow valves or thermostatic expansion valves (TXV's) in place of electronic expansion valves are not acceptable.

The suction accumulator shall be insulated with minimum 3/8" thick closed cell insulation to prevent condensation. The accumulator's internal oil return port shall be sized properly for the unit's operating range. To ensure proper oil return, suction accumulator shall not be 'oversized'.



## **Piping and Connections**

The unit shall have two sets of primary water in and out connections (for indoor and outdoor loops). The primary connection type shall be 1" nominal female National Pipe Thread (NPT). Domestic hot water (desuperheater) water connectors shall be ½" nominal female National Pipe Thread (NPT). All water connectors shall be rigidly mounted to cabinet with corrosion resistant fasteners to prevent relative movement. All water connectors shall be constructed of copper or brass material for corrosion resistance.

All internal water and refrigerant piping shall be insulated with minimum 3/8" thick closed cell insulation. Insulation consisting of 1/8" closed-cell insulating tape shall not be acceptable.

## **Electrical**

Controls and safety devices shall be factory wired and mounted within the unit. Controls shall include 24 volt alternating current (24VAC) activated compressor contactor, and 24VAC 100VA transformer with built in circuit breaker or fused on both primary and secondary sides. A terminal strip with screw in terminals shall be provided for field control wiring. Units shall be name-plated for use with time delay fuses or circuit breakers. Unit controls shall be 24VAC and provide heating as required by the remote thermostat or controller, or on-board controller. Unit shall provide remote fault indication to the control system via serial communications as well as provide fault messages on the front panel LCD display.

## **Unit Control**

The control system shall have the following features:

1. Anti-short cycle time delay on compressor operation. Time delay shall be a minimum of 5 minutes, for both thermostat demand and safety control reset starts. An override shall be provided to disable this delay for unit commissioning and testing purposes.
2. Random compressor start delay of 0-120 seconds on unit power up to facilitate starting multiple units after a power failure.
3. Compressor shutdown for high or low refrigerant pressures, Loss of Charge (LOC), optional low flow conditions, and for optional phase protection faults on three phase models.
4. Automatic intelligent reset: unit shall automatically restart after a trip short cycle delay expires if after trip if the fault has cleared. Should a fault reoccur 3 times sequentially then permanent lockout shall occur, requiring cycling of the power to the unit in order to reset.
5. Manual reset high pressure in case of electronic board failure.
6. The low pressure shall not be monitored for the first 90 seconds after a compressor start to prevent nuisance safety trips.
7. 2 x 16 backlit Liquid Crystal Display (LCD) and four buttons provide basic configuration and data access. Unit may be configured for stand alone operation.
8. Universal Serial Bus (USB) port for full data access and diagnostic information, including manual override of all inputs and outputs, data-logging, and real-time charting.
9. BACnet connectivity for control by building automation system, and providing alarm feedback.

Maritime Geothermal works continually to improve its products. As a result, the design and specifications of any product may be changed without notice. Please contact Maritime Geothermal at 1-506-756-8135 or visit [www.nordicghp.com](http://www.nordicghp.com) for latest design and specifications. Purchaser's approval of this data set signifies that the equipment is acceptable under the provisions of the job specification. Statements and other information contained herein are not express warranties and do not form the basis of any commercial contract or other agreement between any parties, but are merely Maritime Geothermal's statement of opinion regarding its products.

# Warranty: W-Series

## RESIDENTIAL LIMITED EXPRESS WARRANTY

Unless a statement is specifically identified as a warranty, statements made by Maritime Geothermal Ltd. ("MG") or its representatives relating to MG's products, whether oral, written or contained in any sales literature, catalogue or agreement, are not express warranties and do not form a part of the basis of the bargain, but are merely MG's opinion or commendation of MG's products.

**SET FORTH HERE IS THE ONLY EXPRESS WARRANTY THAT APPLIES TO MG'S PRODUCTS. MG MAKES NO WARRANTY AGAINST LATENT DEFECTS. MG MAKES NO WARRANTY OF MERCHANTABILITY OF THE GOODS OR OF THE FITNESS OF THE GOODS FOR ANY PARTICULAR PURPOSE.**

### LIMITED EXPRESS RESIDENTIAL WARRANTY - PARTS

MG warrants its Residential Class products, purchased and retained in the United States of America and Canada, to be free from defects in material and workmanship under normal use and maintenance as follows:

- (1) Air conditioning, heating and/or heat pump units built or sold by MG ("MG Units") for five (5) years from the Warranty Inception Date (as defined below).
- (2) Thermostats, auxiliary electric heaters and geothermal pumping modules built or sold by MG, when installed with MG Units, for five (5) years from the Warranty Inception Date (as defined below).
- (3) Sealed refrigerant circuit components of MG Units (which components only include the compressor, refrigerant to air/water heat exchangers, reversing valve body and refrigerant metering device) for ten (10) years from the Warranty Inception Date (as defined below).
- (4) Other accessories and parts built or sold by MG, when installed and purchased with MG Units, for five (5) years from the date of shipment from MG.
- (5) Other accessories, when purchased separately, for (1) year from the date of shipment from MG.

**The "Warranty Inception Date" shall be the date of original unit installation, as per the date on the installation Startup Record; or six (6) months from date of unit shipment from MG, whichever comes first.**

To make a claim under this warranty, parts must be returned to MG in Petiscodiac, New Brunswick, freight prepaid, no later than ninety (90) days after the date of the failure of the part. If MG determines the part to be defective and within MG's Limited Express Residential Warranty, MG shall, when such part has been either replaced or repaired, return such to a factory recognized distributor, dealer or service organization, freight prepaid. The warranty on any part repaired or replaced under warranty expires at the end of the original warranty period.

### LIMITED EXPRESS RESIDENTIAL WARRANTY - LABOUR

This Limited Express Residential Labour Warranty shall cover the **labour** incurred by MG authorized service personnel in connection with the installation of a new or repaired warranty part that is covered by this Limited Express Residential Warranty only to the extent specifically set forth in the current **labour** allowance schedule "A" provided by MG's Warranty Department and only as follows:

- (1) MG Units for two (2) years from the Warranty Inception Date.
- (2) Thermostats, auxiliary electric heaters and geothermal pump modules built or sold by MG, when installed with MG Units, for two (2) years from the Warranty Inception Date.
- (3) Sealed refrigerant circuit components of MG Units (which components only include the compressor, refrigerant to air/water heat exchangers, reversing valve body and refrigerant metering device) for five (5) years from the Warranty Inception Date.

**Labour** costs are not covered by this Limited Express Residential Warranty to the extent they **exceed** the amount allowed under said allowance schedule, they are not specifically provided for in said allowance schedule, they are not the result of work performed by MG authorized service personnel, they are incurred in connection with a part not covered by this Limited Express Residential Warranty, or they are incurred more than the time periods set forth in this paragraph after the Warranty Inception Date.

This warranty does not cover and does not apply to:

- (1) Air filters, fuses, refrigerant, fluids, oil.
- (2) Products relocated after initial installation.
- (3) Any portion or component of any system that is not supplied by MG, regardless of the cause of the failure of such portion or component.
- (4) Products on which the unit identification tags or labels have been removed or defaced.
- (5) Products on which payment to MG, or to the owner's seller or installing contractor, is in default.
- (6) Products subjected to improper or inadequate installation, maintenance, repair, wiring or voltage conditions.
- (7) Products subjected to accident, misuse, negligence, abuse, fire, flood, lightning, unauthorized alteration, misapplication, contaminated or corrosive liquid or air supply, operation at abnormal air or liquid temperatures or flow rates, or opening of the refrigerant circuit by unqualified personnel.
- (8) Mold, fungus or bacteria damage
- (9) Corrosion or abrasion of the product.
- (10) Products supplied by others.
- (11) Products which have been operated in a manner contrary to MG's printed instructions.
- (12) Products which have insufficient performance as a result of improper system design or improper application, installation, or use of MG's products.
- (13) Electricity or fuel, or any increases or unrealized savings in same, for any reason whatsoever.

Except for the limited **labour** allowance coverage set forth above, MG is not responsible for:

- (1) The costs of fluids, refrigerant or system components **supplied by others**, or associated **labour** to repair or replace the same, which is incurred as a result of a defective part covered by MG's Limited Residential Warranty.
- (2) The costs of **labour**, refrigerant, materials or service incurred in diagnosis and removal of the defective part, or in obtaining and replacing the new or repaired part.
- (3) Transportation costs of the defective part from the installation site to MG, or of the return of that part if not covered by MG's Limited Express Residential Warranty.
- (4) The costs of normal maintenance.

This Limited Express Residential Warranty applies to MG Residential Class products manufactured on or after February 15, 2010. MG'S LIABILITY UNDER THE TERMS OF THIS LIMITED WARRANTY SHALL APPLY ONLY TO THE MG UNITS REGISTERED WITH MG THAT BEAR THE MODEL AND SERIAL NUMBERS STATED ON THE INSTALLATION START UP RECORD, AND MG SHALL NOT, IN ANY EVENT, BE LIABLE UNDER THE TERMS OF THIS LIMITED WARRANTY UNLESS THIS INSTALLATION START UP RECORD HAS BEEN ENDORSED BY OWNER & DEALER/INSTALLER AND RECEIVED BY MG LIMITED WITHIN 90 DAYS OF START UP.

**Limitation:** This Limited Express Residential Warranty is given in lieu of all other warranties. If, notwithstanding the disclaimers contained herein, it is determined that other warranties exist, any such express warranty, including without limitation any express warranties or any implied warranties of fitness for particular purpose and merchantability, shall be limited to the duration of the Limited Express Residential Warranty.

### LIMITATION OF REMEDIES

In the event of a breach of the Limited Express Residential Warranty, MG will only be obligated at MG's option to repair the failed part or unit, or to furnish a new or rebuilt part or unit in exchange for the part or unit which has failed. If after written notice to MG's factory in Petiscodiac, New Brunswick of each defect, malfunction or other failure, and a reasonable number of attempts by MG to correct the defect, malfunction or other failure, and the remedy fails of its essential purpose, MG shall refund the purchase price paid to MG in exchange for the return of the sold good(s). Said refund shall be the maximum liability of MG. **THIS REMEDY IS THE SOLE AND EXCLUSIVE REMEDY OF THE BUYER OR PURCHASER AGAINST MG FOR BREACH OF CONTRACT, FOR THE BREACH OF ANY WARRANTY OR FOR MG'S NEGLIGENCE OR IN STRICT LIABILITY.**

### LIMITATION OF LIABILITY

MG shall have no liability for any damages if MG's performance is delayed for any reason or is prevented to any extent by any event such as, but not limited to: any war, civil unrest, government restrictions or restraints, strikes, or work stoppages, fire, flood, accident, shortages of transportation, fuel, material, or labour, acts of God or any other reason beyond the sole control of MG. **MG EXPRESSLY DISCLAIMS AND EXCLUDES ANY LIABILITY FOR CONSEQUENTIAL OR INCIDENTAL DAMAGE IN CONTRACT, FOR BREACH OF ANY EXPRESS OR IMPLIED WARRANTY, OR IN TORT, WHETHER FOR MG'S NEGLIGENCE OR AS STRICT LIABILITY.**

### OBTAINING WARRANTY PERFORMANCE

Normally, the dealer or service organization who installed the products will provide warranty performance for the owner. Should the installer be unavailable, contact any MG recognized distributor, dealer or service organization. If assistance is required in obtaining warranty performance, write or call Maritime Geothermal Ltd.

NOTE: Some states or Canadian provinces do not allow limitations on how long an implied warranty lasts, or the limitation or exclusions of consequential or incidental damages, so the foregoing exclusions and limitations may not apply to you. This warranty gives you specific legal rights, and you may also have other rights which vary from state to state and from Canadian province to Canadian province.